

**50TC
Single Package Rooftop, 50Hz
Cooling Only
Sizes 07, 08, 09, and 12
with Puron® (R-410A) Refrigerant**



Turn to the Experts.™

Installation Instructions

NOTE: This manual discusses only the mechanical installation of this unit. Star-up procedures, operating sequences and service instructions are included in a separate Service/Maintenance manual which is not included with this unit. Other manuals may be required for specific factory-installed options.

Read through the entire installation instruction manual before starting the installation, to familiarize yourself with all steps and to identify additional reference materials required.

Contact your local Carrier representative for additional service reference materials.

TABLE OF CONTENTS

SAFETY CONSIDERATIONS	1
INSTALLATION	6
Step 1 - Plan for Unit Location	6
Step 2 - Plan for Sequence of Unit Installation	7
Step 3 - Inspect Unit	7
Step 4 - Provide Unit Support	7
Step 5 - Field Fabricate Ductwork	10
Step 6 - Rig and Place Unit	11
Step 7 - Convert to Horizontal & Connect Ductwork	11
Step 8 - Install Outside Air Hood	11
Step 9 - Install External Condensate Trap and Line	13
Step 10 - Make Electrical Connections	13
Step 11 - Adjust Factory-Installed Options	35
Step 12 - Install Accessories	35

SAFETY CONSIDERATIONS

Improper installation, adjustment, alteration, service, maintenance, or use can cause explosion, fire, electrical shock or other conditions which may cause personal injury or property damage. Consult a qualified installer, service agency, or your distributor or branch for information or assistance. The qualified installer or agency must use factory-authorized kits or accessories when modifying this product. Refer to the individual instructions packaged with the kits or accessories when installing.

Follow all safety codes. Wear safety glasses and work gloves. Use quenching cloths for brazing operations and have a fire extinguisher available. Read these instructions thoroughly and follow all warnings or cautions attached to the unit. Consult local building codes for special requirements. In absence of local codes, it is recommended that the USA standard ANSI/NFPA 70, National Electrical Code (NEC), be followed.

It is important to recognize safety information. This is the safety-alert symbol . When you see this symbol on the unit and in instructions or manuals, be alert to the potential for personal injury.

Understand the signal words DANGER, WARNING, CAUTION, and NOTE. These words are used with the safety-alert symbol. DANGER identifies the most serious hazards which **will** result in severe personal injury or death. WARNING signifies hazards which **could** result in personal injury or death. CAUTION is used to identify unsafe practices, which **may** result in minor personal injury or product and property damage. NOTE is used to highlight suggestions which **will** result in enhanced installation, reliability, or operation.

⚠ WARNING

ELECTRICAL SHOCK HAZARD

Failure to follow this warning could cause personal injury or death.

Before performing service or maintenance operations on unit, always turn off main power switch to unit and install lockout tag. Unit may have more than one power switch.

⚠ WARNING

UNIT OPERATION AND SAFETY HAZARD

Failure to follow this warning could cause personal injury, death and/or equipment damage.

Puron® (R-410A) refrigerant systems operate at higher pressures than standard R-22 systems. Do not use R-22 service equipment or components on Puron refrigerant equipment.

⚠ WARNING

PERSONAL INJURY AND ENVIRONMENTAL HAZARD

Failure to follow this warning could cause personal injury or death.

Relieve pressure and recover all refrigerant before system repair or final unit disposal.

Wear safety glasses and gloves when handling refrigerants. Keep torches and other ignition sources away from refrigerants and oils.



⚠ CAUTION

CUT HAZARD

Failure to follow this caution may result in personal injury.

Sheet metal parts may have sharp edges or burrs. Use care and wear appropriate protective clothing, safety glasses and gloves when handling parts and servicing furnaces.

NOTES:

1. DIMENSIONS ARE IN INCHES, DIMENSIONS IN [] ARE IN MILLIMETERS.
2.  CENTER OF GRAVITY
3.  DIRECTION OF AIR FLOW

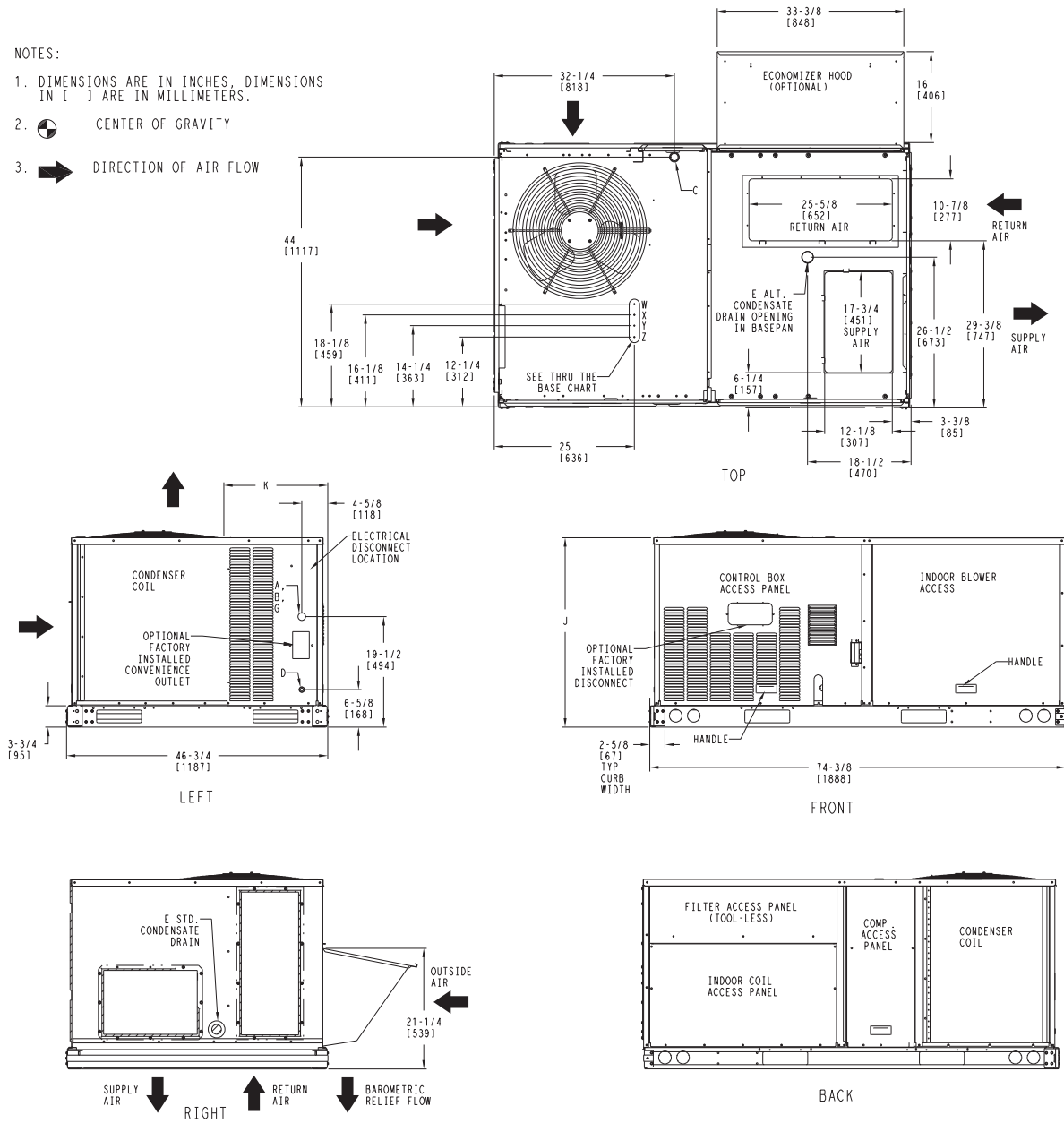

Vertical Connections / Economizer

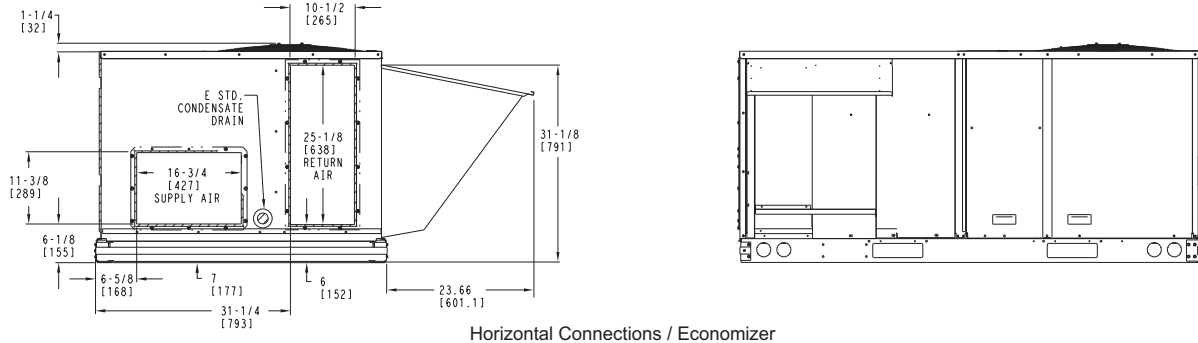

Horizontal Connections / Economizer

CONNECTION SIZES	
A	1 3/8" [35] DIA FIELD POWER SUPPLY HOLE
B	2" [50] DIA POWER SUPPLY KNOCKOUT
C	1 3/4" [51] DIA GAUGE ACCESS PLUG
D	7/8" [22] DIA FIELD CONTROL WIRING HOLE
E	3/4"-14 NPT CONDENSATE DRAIN
G	2 1/2" [64] DIA POWER SUPPLY KNOCK-OUT

THRU-THE-BASE CHART THESE HOLES REQUIRED FOR USE CRBTMPWR001A01, 003A01			
THREADED CONDUIT SIZE	WIRE USE	REQ'D HOLE SIZES (MAX.)	
W	1/2"	ACC.	7/8" [22.2]
X	1/2"	24V	7/8" [22.2]
Y*	3/4" (001,003)	POWER	1 1/8" [28.4]
Z**	(003) 1/2" FPT	GAS	1 3/16" [30.0]

FOR "THRU-THE-BASEPAN" FACTORY OPTION, FITTINGS FOR ONLY X, Y, & Z ARE PROVIDED

* SELECT EITHER 3/4" OR 1/2" FOR POWER, DEPENDING ON WIRE SIZE

** (001) PROVIDES 3/4" FPT THRU CURB FLANGE & FITTING.

UNIT	J	K
50TC-A07	41 3/8 [1051]	14 7/8 [377]

50TC

Fig. 1 - Unit Dimensional Drawing - 07 Size Units

UNIT	STD. UNIT WEIGHT		CORNER WEIGHT (A)		CORNER WEIGHT (B)		CORNER WEIGHT (C)		CORNER WEIGHT (D)		C.G.		HEIGHT
	KG.	LBS.	KG.	LBS.	KG.	LBS.	KG.	LBS.	KG.	LBS.	X	Y	Z
50TC-A07	275	607	68	150	73	160	69	153	65	144	38 [965]	22 [559]	20 3/4 [527]

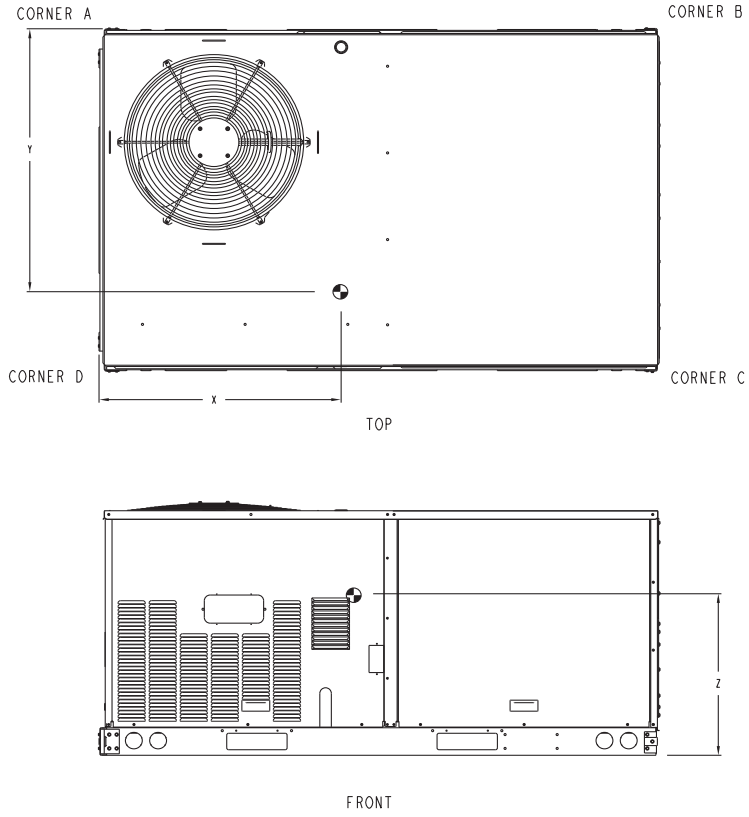

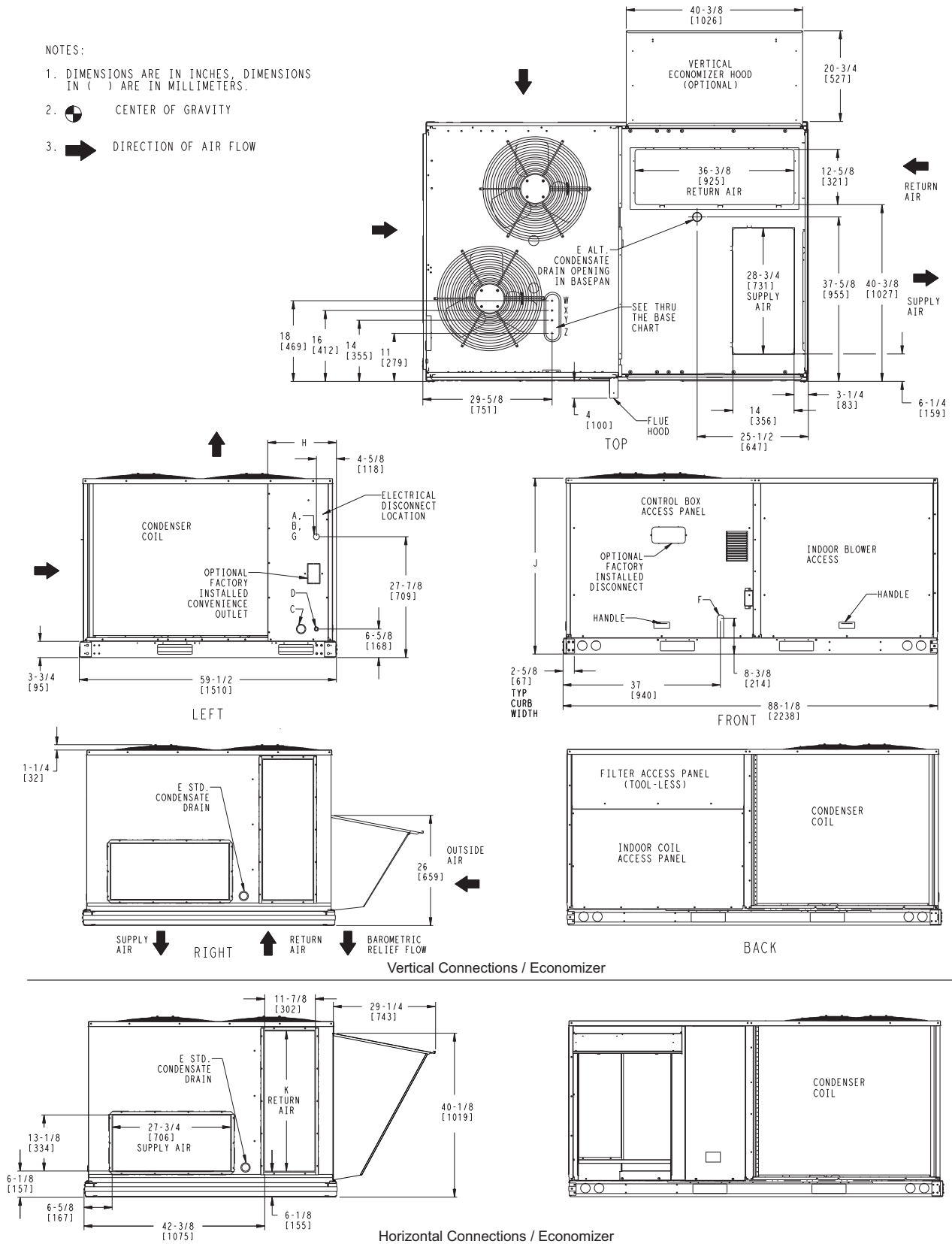

Fig. 1 - Unit Dimensional Drawing – 07 Size Unit (cont.)

C09448

NOTES:

1. DIMENSIONS ARE IN INCHES, DIMENSIONS IN () ARE IN MILLIMETERS.
2.  CENTER OF GRAVITY
3.  DIRECTION OF AIR FLOW



CONNECTION SIZES	
A	1 3/8" DIA [35] FIELD POWER SUPPLY HOLE
B	2 1/2" [64] DIA POWER SUPPLY KNOCKOUT
C	1 3/4" DIA [51] GAUGE ACCESS PLUG
D	7/8" DIA [22] FIELD CONTROL WIRING HOLE
E	3/4"-14 NPT CONDENSATE DRAIN
G	2" DIA [51] POWER SUPPLY KNOCK-OUT

THRU-THE-BASE CHART THESE HOLES REQUIRED FOR USE CRBTPWR002A01			
	THREADED CONDUIT SIZE	WIRE USE	REQ'D HOLE SIZES (MAX.)
W	1/2"	ACC.	7/8" (22.2)
X	1/2"	24V	7/8" (22.2)
Y	1 1/4" (002)	POWER	1 3/4" (44.4)

FOR "THRU-THE-BASEPAN" FACTORY OPTION, FITTINGS FOR ONLY X & Y ARE PROVIDED

UNIT	J	K	H
50TC-D08	41 1/4 [1048]	33 [658]	15 7/8 [403]
50TC-D09	49 3/8 [1253]	37 1/4 [946]	15 7/8 [403]
50TC-D12	49 3/8 [1253]	37 1/4 [946]	15 7/8 [403]

Fig. 2 - Unit Dimensional Drawing – 08, 09 and 12 Size Units

50TC

UNIT	STD. UNIT WEIGHT *		CORNER WEIGHT (A)		CORNER WEIGHT (B)		CORNER WEIGHT (C)		CORNER WEIGHT (D)		C.G.		
	LBS.	KG.	LBS.	KG.	LBS.	KG.	LBS.	KG.	LBS.	KG.	X	Y	Z
50TC-D08	750	340.5	156	70.8	153	69.5	219	99.4	222	100.8	43 3/4 [1111.3]	35 [889]	20 [508]
50TC-D09	855	388.2	223	101.2	171	77.6	200	90.8	261	118.5	38 3/8 [975]	32 1/8 [816]	19 1/8 [486]
50TC-D12	865	392.7	225	102.2	173	78.5	203	92.2	264	120	38 3/8 [975]	32 1/8 [816]	19 1/8 [486]

* STANDARD UNIT WEIGHT IS WITHOUT ELECTRIC HEAT AND WITHOUT PACKAGING. FOR OTHER OPTIONS AND ACCESSORIES, REFER TO THE PRODUCT DATA CATALOG.

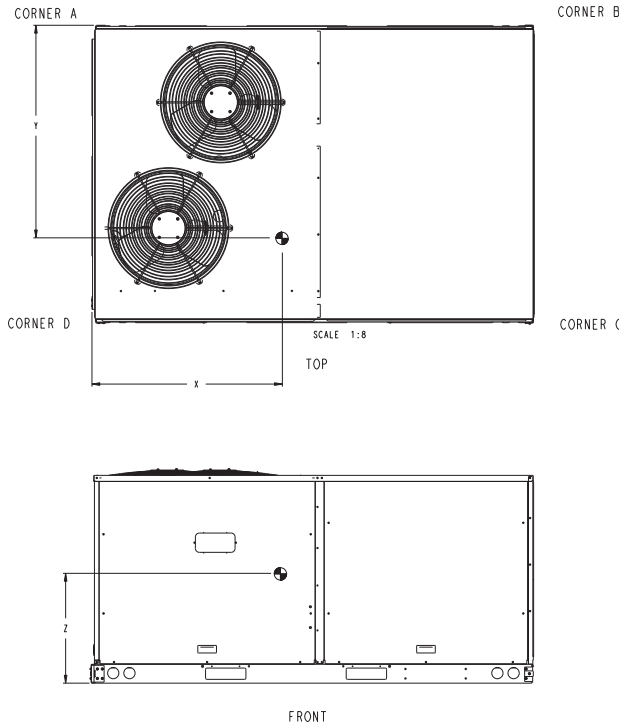

Fig. 2 - Unit Dimensional Drawing – 08, 09 and 12 Size Units (cont.)

C09451

INSTALLATION

Jobsite Survey

Complete the following checks before installation.

1. Consult local building codes or the U.S.A. National Electrical Code (Ref: ANSI/NFPA 70, [American National Standards Institute/National Fire Protection Association], latest revision) for special installation requirements.
2. Determine unit location (from project plans) or select unit location.
3. Check for possible overhead obstructions which may interfere with unit lifting or rigging.

Step 1 — Plan for Unit Location

Select a location for the unit and its support system (curb or other) that provides for the minimum clearances required for safety. This includes the clearance to combustible surfaces, unit performance and service access below, around and above unit as specified in unit drawings. See Fig. 3.

NOTE: Consider also the effect of adjacent units.

Unit may be installed directly on wood flooring or on approved roof-covering material when roof curb is used.

Do not install unit in an indoor location. Do not locate air inlets near exhaust vents or other sources of contaminated air.

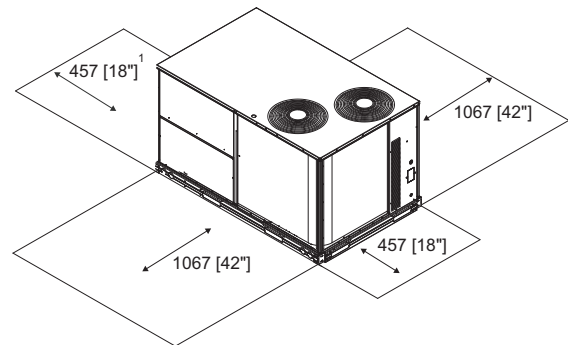

¹ Required bottom condensate drain connection. Otherwise, 914mm [36"] for condensate connection.

Fig. 3 - Service Clearance Dimensional Drawing

C09454

Although unit is weatherproof, avoid locations that permit water from higher level runoff and overhangs to fall onto the unit.

Select a unit mounting system that provides adequate height to allow installation of condensate trap per requirements. Refer to Step 9 — Install External Condensate Trap and Line – for required trap dimensions.

Roof mount —

Check building codes for weight distribution requirements. Unit operating weight is shown in Table 1.

Table 1 – Operating Weights

50TC– Component	UNITS KG (LB)			
	A07	D08	D09	D12
Base Unit	275 (607)	340.5 (750)	388.2 (855)	392.7 (865)
Economizer				
Vertical	36 (80)	36 (80)	36 (80)	36 (80)
Horizontal	48 (105)	48 (105)	48 (105)	48 (105)
Curb				
356 mm/14-in	60 (133)	60 (133)	65 (143)	60 (133)
610 mm/24-in	79 (174)	79 (174)	69 (153)	79 (174)

Step 2 — Plan for Sequence of Unit Installation

The support method used for this unit will dictate different sequences for the steps of unit installation. For example, on curb-mounted units, some accessories must be installed on the unit before the unit is placed on the curb. Review the following for recommended sequences for installation steps.

Curb-mounted installation —

- Install curb
- Install field-fabricated ductwork inside curb
- Install accessory thru-base service connection package (affects curb and unit) (refer to accessory installation instructions for details)
- Prepare bottom condensate drain connection to suit planned condensate line routing (refer to Step 9 for details)
- Rig and place unit
- Install outdoor air hood
- Install condensate line trap and piping
- Make electrical connections
- Install other accessories

Pad-mounted installation —

- Prepare pad and unit supports
- Check and tighten the bottom condensate drain connection plug
- Rig and place unit
- Convert unit to side duct connection arrangement
- Install field-fabricated ductwork at unit duct openings
- Install outdoor air hood
- Install condensate line trap and piping
- Make electrical connections
- Install other accessories

Frame-mounted installation —

Frame-mounted applications generally follow the sequence for a curb installation. Adapt as required to suit specific installation plan.

Step 3 — Inspect unit

Inspect unit for transportation damage. File any claim with transportation agency.

Confirm before installation of unit that voltage, amperage and circuit protection requirements listed on unit data plate agree with power supply provided.

Step 4 — Provide Unit Support

Roof Curb Mount —

Accessory roof curb details and dimensions are shown in Fig. 4 (size 07 units) and Fig. 5 (size 08 – 12 units). Assemble and install accessory roof curb in accordance with instructions shipped with the curb.

NOTE: The gasketing of the unit to the roof curb is critical for a watertight seal. Install gasket supplied with the roof curb as shown in Fig. 4 and Fig. 5. Improperly applied gasket can also result in air leaks and poor unit performance.

Curb should be level. This is necessary for unit drain to function properly. Unit leveling tolerances are show in Fig. 6. Refer to Accessory Roof Curb Installation Instructions for additional information as required.

Install insulation, cant strips, roofing felt, and counter flashing as shown. *Ductwork must be attached to curb and not to the unit. The accessory thru-the-base power package must be installed before the unit is set on the roof curb.*

If electric and control wiring is to be routed through the basepan, attach the accessory thru-the-base service connections to the basepan in accordance with the accessory installation instructions.

Slab Mount (Horizontal Units Only) —

Provide a level concrete slab that extends a minimum of 150 mm (6 in.) beyond unit cabinet. Install a gravel apron in front of condenser coil air inlet to prevent grass and foliage from obstructing airflow.

NOTE: Horizontal units may be installed on a roof curb if required.

Alternate Unit Support (In Lieu of Curb or Slab Mount) —

A non-combustible sleeper rail can be used in the unit curb support area. If sleeper rails cannot be used, support the long sides of the unit with a minimum of 3 equally spaced 102 mm x 102 mm (4-in. x 4-in.) pads on each side.

50TC

CONNECTOR PKG. ACCY.	B	C	D ALT DRAIN HOLE	POWER	CONTROL	ACCESSORY POWER
CRBTMPWR003A01	1'-9 11/16" [551]	1'-4" [406]	1 3/4" [44.5]	3/4" [19] NPT	1/2" [12.7] NPT	1/2" [12.7] NPT
CRBTMPWR004A01				1 1/4" [31.7]		

ROOFCURB ACCESSORY	A	UNIT SIZE
CRRFCURB001A01	1'-2" [356]	50TC-A07
CRRFCURB002A01	2'-0" [610]	

NOTES:

1. Roof curb accessory is shipped disassembled.
2. Insulated panels.
3. Dimensions in [] are in millimeters.
4. Roof curb: galvanized steel.
5. Attach ductwork to curb (flanges of duct rest on curb).
6. Service clearance: 4 ft on each side.
7.  Direction of airflow.

50TC

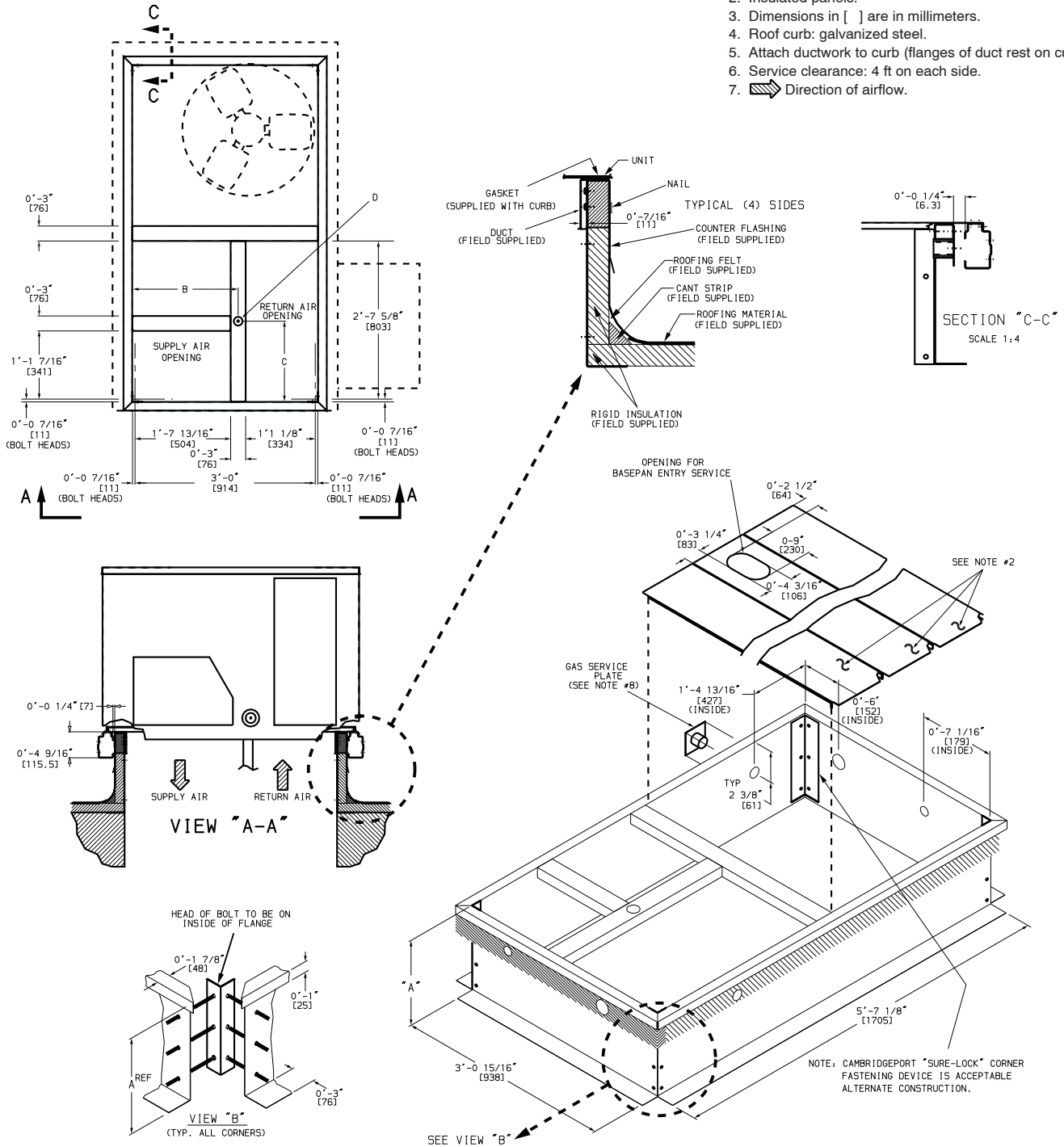

Fig. 4 - Roof Curb Details - 07 Size Units

C09452

50TC

ROOFCURB ACCESSORY	A	UNIT SIZE
CRRFCURB003A01	1'-2" [356]	50TC-08-12
CRRFCURB004A01	2'-0" [610]	

NOTES:

1. ROOFCURB ACCESSORY IS SHIPPED DISASSEMBLED.
2. INSULATED PANELS: 1" THK. POLYURETHANE FOAM, 1-3/4 # DENSITY.
3. DIMENSIONS IN [] ARE IN MILLIMETERS.
4. ROOFCURB: 16 GAGE STEEL.
5. ATTACH DUCTWORK TO CURB. (FLANGES OF DUCT REST ON CURB)
6. SERVICE CLEARANCE 4' ON EACH SIDE.
7. DIRECTION OF AIR FLOW.
8. CONNECTOR PACKAGES CRBTMPWR001A01 AND 2A01 ARE FOR THRU-THE-CURB GAS TYPE. PACKAGES CRBTMPWR003A01 AND 4A01 ARE FOR THE THRU-THE-BOTTOM TYPE GAS CONNECTIONS.

CONNECTOR PKG. ACC.	B	C	D ALT DRAIN HOLE	GAS	POWER	CONTROL	ACCESSORY PWR
CRBTMPWR001A01 CRBTMPWR002A01	2'-8 7/16" [827]	1'-10 15/16" [583]	1 3/4" [44.5]	3/4" [19]NPT	3/4" [19]NPT 1 1/4" [31.7]	1/2" [12.7]NPT	1/2" [12.7]NPT
CRBTMPWR003A01				1/2" [12.7]NPT	3/4" [19]NPT		
CRBTMPWR004A01				3/4" [19]NPT	1 1/4" [31.7]		

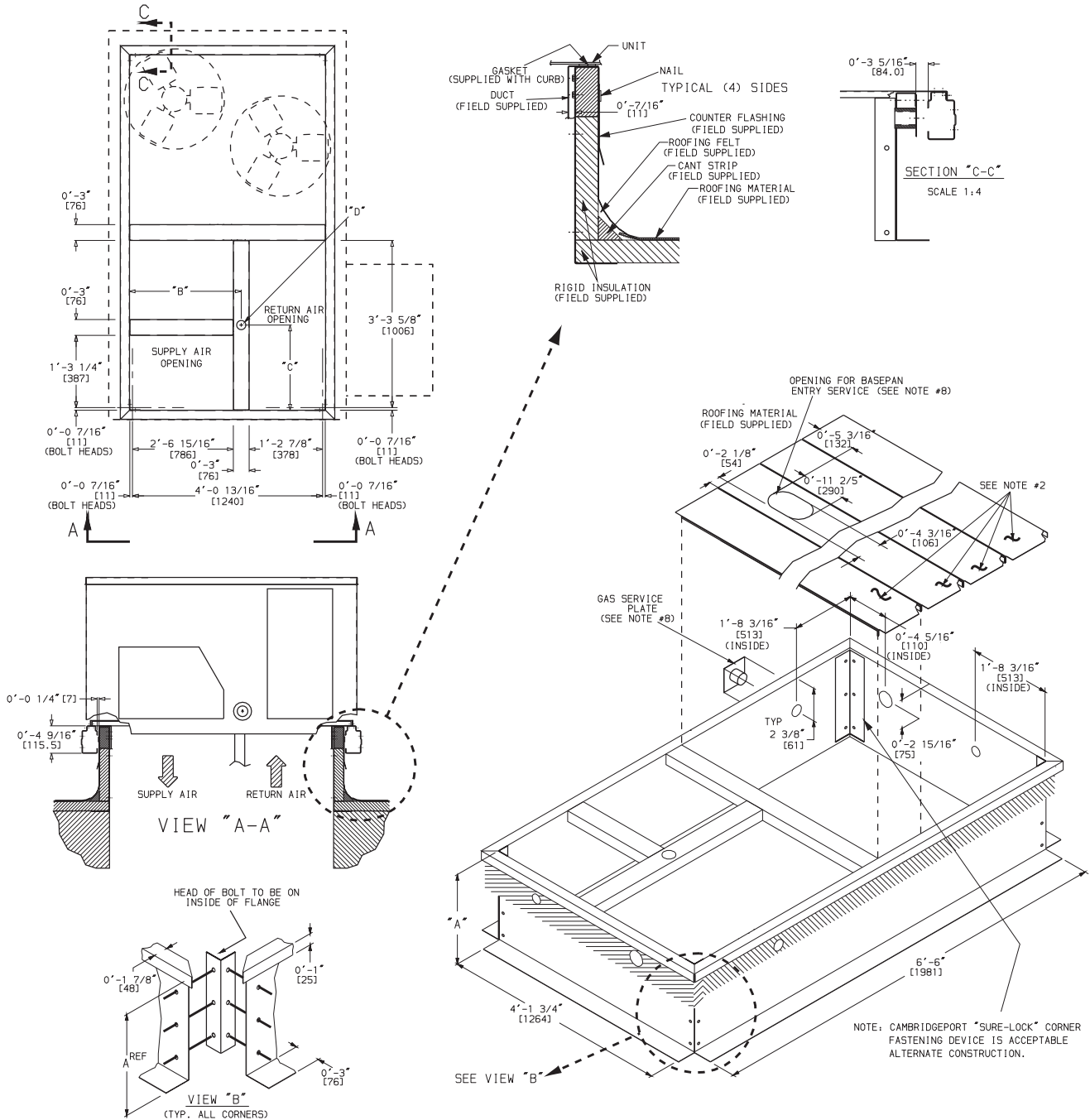

Fig. 5 - Roof Curb Details - 08 - 12 Size Units

C09453

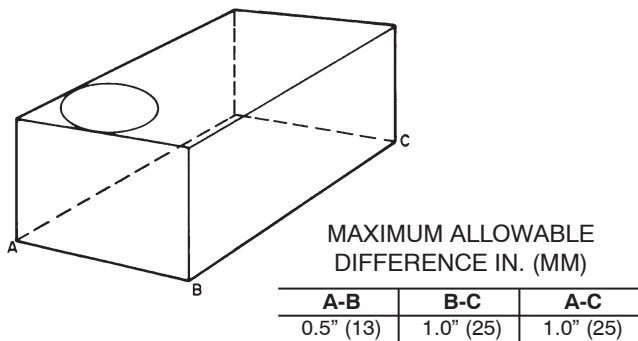

Fig. 6 - Unit Leveling Tolerances

C06110

Step 5 — Field Fabricate Ductwork

Cabinet return-air static pressure (a negative condition) shall not exceed 87 Pa (0.35 in. wg) with economizer or 112 Pa (0.45 in. wg) without economizer.

For vertical ducted applications, secure all ducts to roof curb and building structure. *Do not connect ductwork to unit.*

Insulate and weatherproof all external ductwork, joints, and roof openings with counter flashing and mastic in accordance with applicable codes.

Ducts passing through unconditioned spaces must be insulated and covered with a vapor barrier.

If a plenum return is used on a vertical unit, the return should be ducted through the roof deck to comply with applicable fire codes.

For units with accessory electric heaters: Horizontal applications require a minimum clearance to combustible surfaces of 25 mm (1-in) from duct for first 305 mm (12-in) away from unit. Vertical applications do not require a minimum clearance.

Minimum clearance is not required around ductwork.

50TC

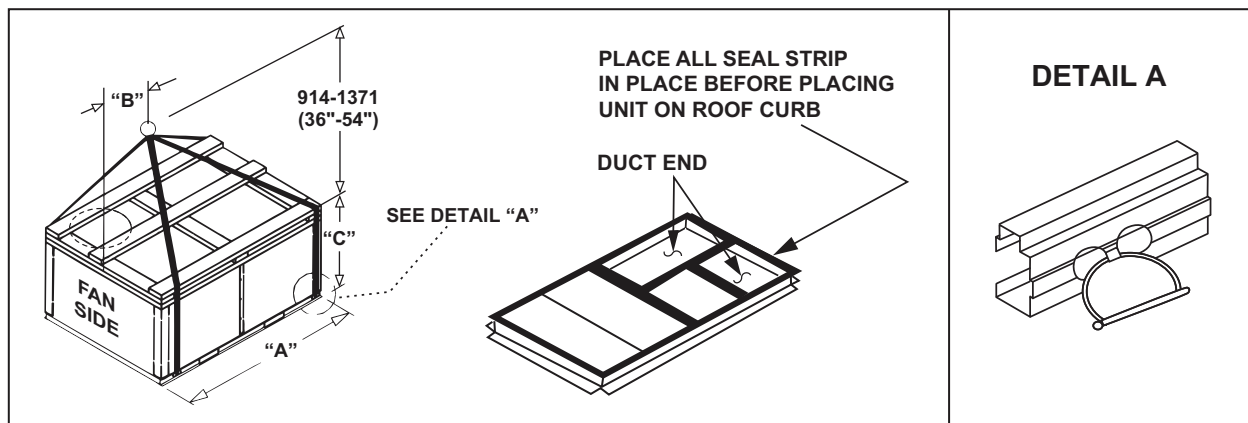

C09458

UNIT	MAX WEIGHT		DIMENSIONS					
			A		B		C	
	KG	LB	MM	IN	MM	IN	MM	IN
50TC-A07	336	740	1890	74.5	965	38.0	850	33.5
50TC-D08	641	1410	2235	88.0	1040	41.0	1055	41.5
50TC-D09	693	1525	2235	88.0	1030	40.5	1255	49.5
50TC-D12	711	1565	2235	88.0	1015	40.0	1255	49.5

NOTES:

1. Dimensions in () are in inches.
2. Hook rigging shackles through holes in base rail, as shown in detail "A." Holes in base rails are centered around the unit center of gravity. Use wooden top to prevent rigging straps from damaging unit.

Fig. 7 - Rigging Details

Step 6 — Rig and Place Unit

Keep unit upright and do not drop. Spreader bars are not required if top crating is left on unit. Rollers may be used to move unit across a roof. Level by using unit frame as a reference. See Table 1 and Fig. 7 for additional information.

Lifting holes are provided in base rails as shown in Fig. 7. Refer to rigging instructions on unit.

⚠ CAUTION

UNIT DAMAGE HAZARD

Failure to follow this caution may result in equipment damage.

All panels must be in place when rigging. Unit is not designed for handling by fork truck.

Before setting the unit onto the curb, recheck gasketing on curb.

Positioning on Curb —

Position unit on roof curb so that the following clearances are maintained: 6.4 mm ($1/4$ in.) clearance between the roof curb and the base rail inside the front and back, 0.0 mm (0.0 in.) clearance between the roof curb and the base rail inside on the duct end of the unit. This will result in the distance between the roof curb and the base rail inside on the condenser end of the unit being approximately equal to section C-C in Figs. 4 and 5.

Although unit is weatherproof, guard against water from higher level runoff and overhangs.

After unit is in position, remove rigging skids and shipping materials.

Step 7 — Convert to Horizontal and Connect Ductwork (when required)

Unit is shipped in the vertical duct configuration. Unit *without* factory-installed economizer or return air smoke detector option may be field-converted to horizontal ducted configuration. To convert to horizontal configuration, remove screws from side duct opening covers and remove covers. Using the same screws, install covers on vertical duct openings with the insulation-side down. Seals around duct openings must be tight. See Fig. 8.

Field-supplied flanges should be attached to horizontal duct openings and all ductwork should be secured to the flanges. Insulate and weatherproof all external ductwork, joints, and roof or building openings with counter flashing and mastic in accordance with applicable codes.

Do not cover or obscure visibility to the unit's informative data plate when insulating horizontal ductwork.

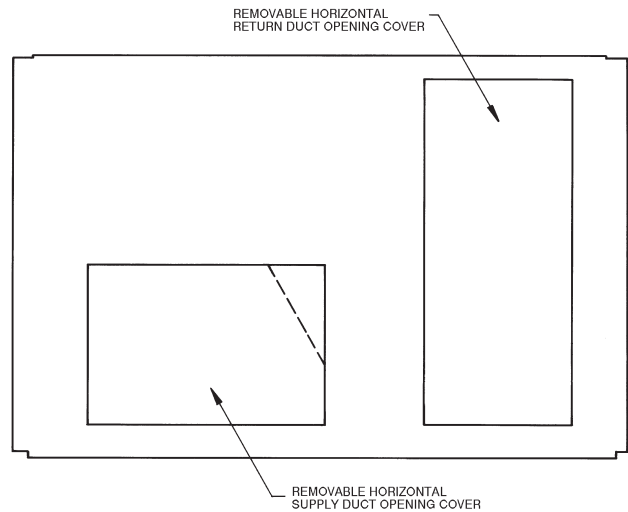

C06108

Fig. 8 - Horizontal Conversion Panels

Step 8 — Install Outside Air Hood

Economizer Hood Removal and Setup - Factory Option

1. The hood is shipped in knock-down form and located in the return air compartment. It is attached to the economizer using two plastic tie-wraps.
2. To gain access to the hood, remove the filter access panel. (See Fig. 9.)
3. Locate and cut the (2) plastic tie-wraps, being careful to not damage any wiring. (See Fig. 10.)
4. Carefully lift the hood assembly through the filter access opening and assemble per the steps outlined in *Economizer Hood and Two-Position Hood* on page 12.

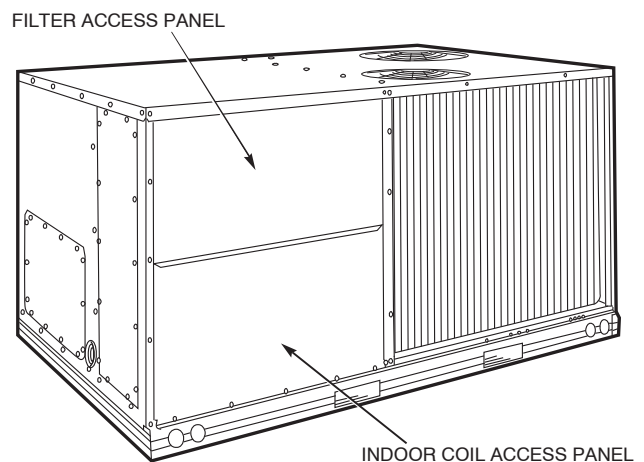

C06023

Fig. 9 - Typical Access Panel Locations

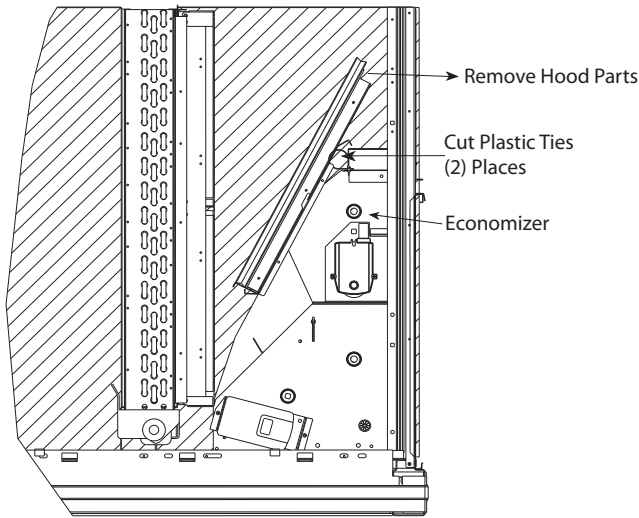

C08633

Fig. 10 - Economizer Parts, Shipping Location

Two Position Damper Hood Removal and Setup - Factory Option

1. The hood is shipped in knock-down form and assembled to a metal support tray using plastic stretch wrap. Located in the return air compartment, the assembly's metal tray is attached to the basepan and also attached to the damper using two plastic tie-wraps.
2. To gain access to the hood, remove the filter access panel. (See Fig. 9.)
3. Locate the (2) screws holding the metal tray to the basepan and remove. Locate and cut the (2) plastic tie-wraps securing the assembly to the damper. (See Fig. 11.) Be careful to not damage any wiring or cut tie-wraps securing any wiring.
4. Carefully lift the hood assembly (with metal tray) through the filter access opening and assemble per the steps outlined in the following procedure *Economizer Hood and Two-Position Hood*.

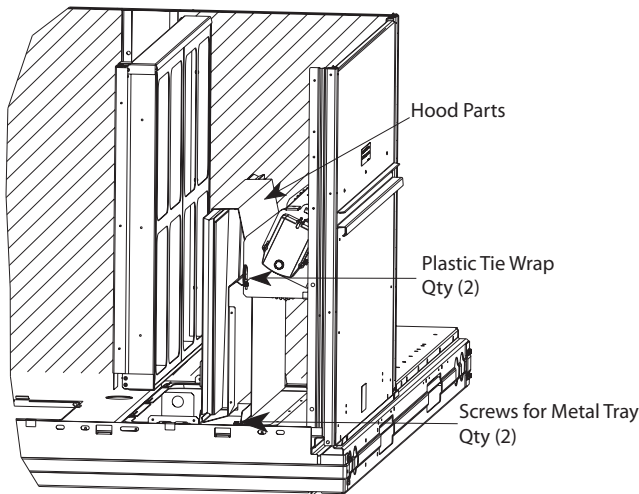

C08639

Fig. 11 - Two-Position Damper, Shipping Location

Economizer Hood and Two-Position Hood—

1. The indoor coil access panel will be used as the top of the hood. Remove the screws along the sides and bottom of the indoor coil access panel. See Fig. 12.

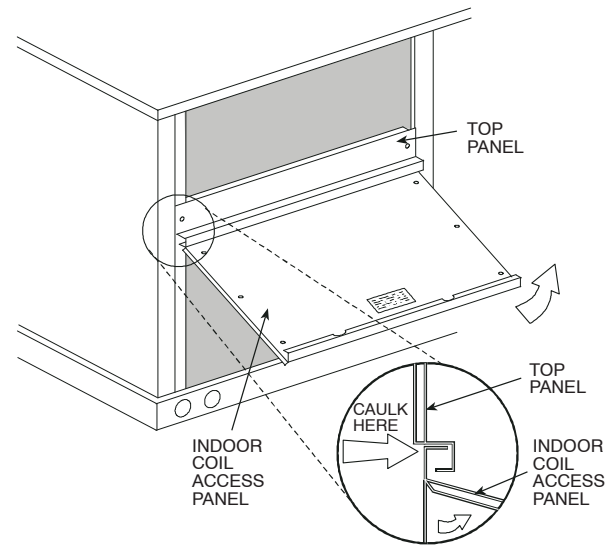

C06025

Fig. 12 - Indoor Coil Access Panel Relocation

2. Swing out indoor coil access panel and insert the hood sides under the panel (hood top). Use the screws provided to attach the hood sides to the hood top. Use screws provided to attach the hood sides to the unit. See Fig. 13.

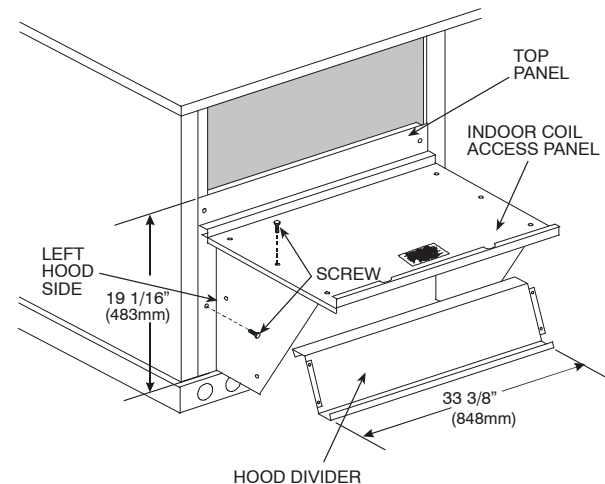

C06026

Fig. 13 - Economizer Hood Construction

3. Remove the shipping tape holding the economizer barometric relief damper in place.
4. Insert the hood divider between the hood sides. See Fig. 13 and 14. Secure hood divider with 2 screws on each hood side. The hood divider is also used as the bottom filter rack for the aluminum filter.

- Open the filter clips which are located underneath the hood top. Insert the aluminum filter into the bottom filter rack (hood divider). Push the filter into position past the open filter clips. Close the filter clips to lock the filter into place. See Fig. 14.

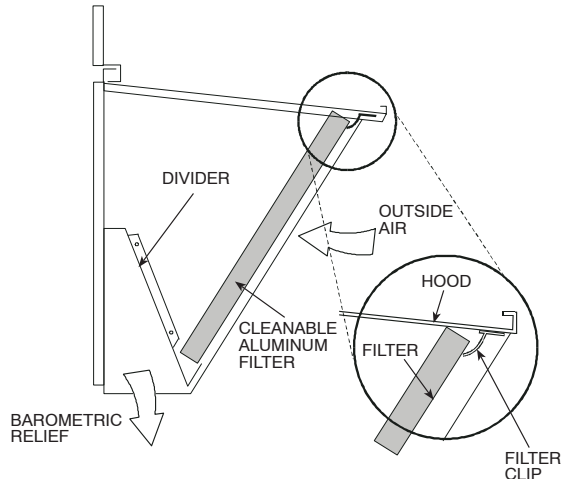

Fig. 14 - Economizer Filter Installation

C08634

- Caulk the ends of the joint between the unit top panel and the hood top.
- Replace the filter access panel.

Step 9 — Install External Condensate Trap and Line

The unit has one 19 mm ($3/4$ -in.) condensate drain connection on the end of the condensate pan and an alternate connection on the bottom. See Fig. 15. Unit airflow configuration does not determine which drain connection to use. Either drain connection can be used with vertical or horizontal applications.

When using the standard side drain connection, ensure the red plug in the alternate bottom connection is tight. Do this before setting the unit in place. The red drain pan can be tightened with a 12.7 mm ($1/2$ -in.) square socket drive extension.

To use the alternate bottom drain connection, remove the red drain plug from the bottom connection (use a 12 mm [$1/2$ -in.] square socket drive extension) and install it in the side drain connection.

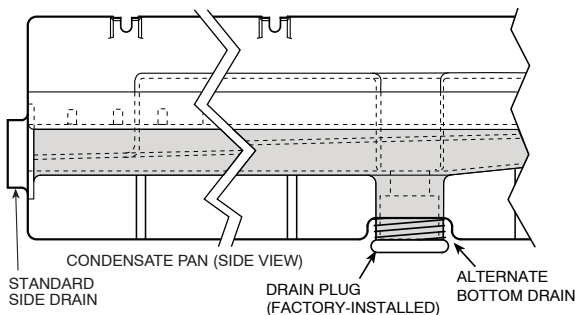
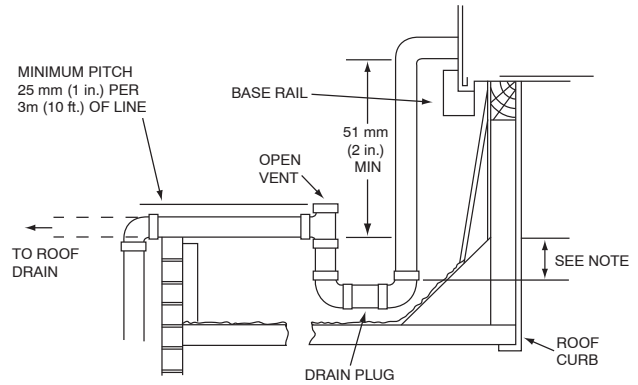

Fig. 15 - Condensate Drain Pan (Side View)

C08021

The piping for the condensate drain and external trap can be completed after the unit is in place. See Fig. 16.



NOTE: Trap should be deep enough to offset maximum unit static difference. A 102 mm (4 in.) trap is recommended

C09387

Fig. 16 - Condensate Drain Piping Details

All units must have an external trap for condensate drainage. Install a trap at least 102 mm (4-in.) deep and protect against freeze-up. If drain line is installed downstream from the external trap, pitch the line away from the unit at 25 mm in 3 m (1-in. per 10 ft) of run. Do not use a pipe size smaller than the unit connection of 19 mm ($3/4$ -in.).

Step 10 — Make Electrical Connections

⚠ WARNING

ELECTRICAL SHOCK HAZARD

Failure to follow this warning could result in personal injury or death.

Do not use gas piping as an electrical ground. Unit cabinet must have an uninterrupted, unbroken electrical ground to minimize the possibility of personal injury if an electrical fault should occur. This ground may consist of electrical wire connected to unit ground lug in control compartment, or conduit approved for electrical ground when installed in accordance with local electrical codes or in absence of local codes, it is recommended that the U.S.A. standard ANSI/NFPA 70, National Electrical Code (NEC), be followed.

NOTE: Check all factory and field electrical connections for tightness. Field-supplied wiring shall conform with the limitations of 33°C (63°F) rise.

Field power wires are connected to the unit at line-side pressure lugs on compressor contactor C and indoor fan contactor IFC (see wiring diagram label for control box component arrangement) or at factory-installed option non-fused disconnect switch. Use copper conductors only.

NOTE: Make field power connections directly to line connection pressure lugs only.

The unit is factory wired for the voltage shown on the nameplate. Refer to the unit label diagram for additional information.

⚠ WARNING

FIRE HAZARD

Failure to follow this warning could result in intermittent operation or performance satisfaction.

Do not connect aluminum wire between disconnect switch and air conditioning unit. Use only copper wire. (See Fig. 17.)

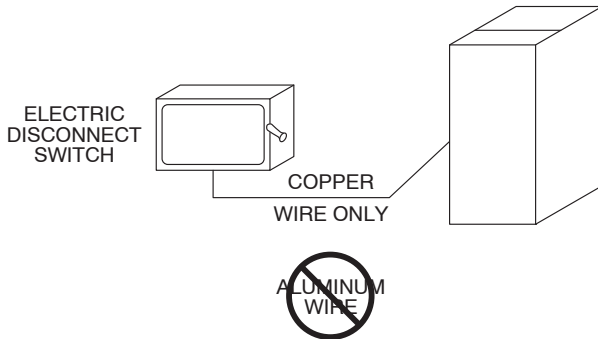

Fig. 17 - Disconnect Switch and Unit

A93033

Units Without Factory-Installed Disconnect —

When installing units, provide a disconnect switch of adequate size per local or national wiring code. Disconnect sizing data is provided on the unit informative plate. Locate on unit cabinet or within sight of the unit per national or local codes. Do not cover unit informative plate if mounting the disconnect on the unit cabinet.

Units with Factory-Installed Disconnect —

The factory-installed option disconnect switch is located in a weatherproof enclosure located under the main control box. The manual switch handle is accessible through an opening in the access panel.

All units -

All field wiring must comply with all local codes. Size wire based on MCA (Minimum Circuit Amps) on the unit informative plate. See Fig. 18 for power wiring connections to the unit power terminal block and equipment ground.

Provide a ground-fault and short-circuit over-current protection device (fuse or breaker) per local code (or U.S.A. NEC Article 440). Refer to unit informative data plate for MOCP (Maximum Over-current Protection) device size.

All field wiring must comply with the appropriate national electrical codes and local requirements.

Units Without Disconnect Option

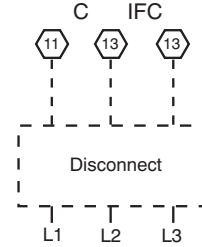

Units With Disconnect Option

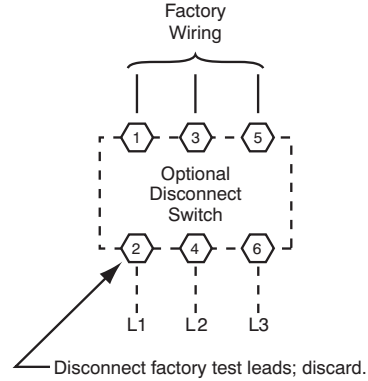

C09411

Fig. 18 - Power Wiring Connections

Table 2 – American/European Wire Conversions

AMERICAN		EUROPEAN
Industry Standard Size	American Conversion (mm ²)	European Standard Size (mm ²)
20 AWG	0.52	0.5
18 AWG	0.82	1.0
16 AWG	1.30	1.5
14 AWG	2.08	2.5

Thru-Base Connections —

This service connection kit consists of a 12.7 mm (¹/₂-in) electrical bulkhead connector and a 31.75 mm (¹/₄-in) electrical bulkhead connector, all factory-installed in the embossed (raised) section of the unit basepan in the condenser section. The 12.7 mm (¹/₂-in) bulkhead connector enables the low-voltage control wires to pass through the basepan. The 31.75 mm (¹/₄-in) electrical bulkhead connector allows the high-voltage power wires to pass through the basepan. See Fig. 19.

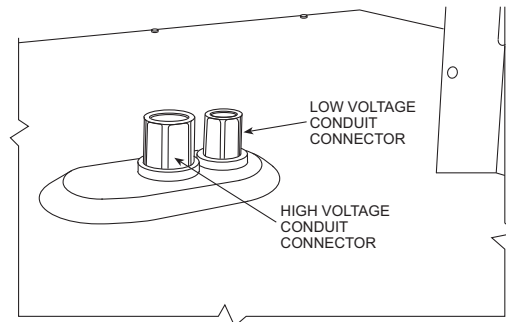

C08637

Fig. 19 - Thru-Base Connection Fittings

Check tightness of connector lock nuts before connecting electrical conduits.

Field-supplied and field-installed liquidtight conduit connectors and conduit may be attached to the connectors on the basepan. Pull correctly rated high voltage and low voltage through appropriate conduits. Connect the power conduit to the internal disconnect (if unit is so equipped) or to the external disconnect (through unit side panel). A hole must be field cut in the main control box bottom on the left side so the 24-v control connections can be made. Connect the control power conduit to the unit control box at this hole.

Units without Thru-Base Connections —

1. Install power wiring conduit through side panel openings. Install conduit between disconnect and control box.
2. Install power lines to terminal connections as shown in Fig. 18.

All Units —

Voltage to compressor terminals during operation must be within voltage range indicated on unit nameplate. On 3-phase units, voltages between phases must be balanced within 2% and the current within 10%. Use the following formula to determine the percent of voltage imbalance.

$$\% \text{ Voltage Imbalance} = 100 \times \frac{\text{max voltage deviation from average voltage}}{\text{average voltage}}$$

C09103

Operation on improper line voltage or excessive phase imbalance constitutes abuse and may cause damage to electrical components. Such operation would invalidate any applicable Carrier warranty.

Field Control Wiring —

The 50TC unit requires an external temperature control device. This device can be a thermostat (field-supplied) or a PremierLink controller (available as factory-installed option or as field-installed accessory, for use on a Carrier Comfort Network or as a stand alone control) or the RTU-MP Controller for Building Management Systems using non-CCN protocols (RTU-MP is available as a factory-installed option only).

Thermostat —

Install a Carrier-approved accessory thermostat according to installation instructions included with the accessory. For complete economizer function, select a two-stage cooling thermostat. Locate the thermostat accessory on a solid wall in the conditioned space to sense average temperature in accordance with the thermostat installation instructions.

If the thermostat contains a logic circuit requiring 24-v power, use a thermostat cable or equivalent single leads of different colors with minimum of seven leads. If the thermostat does not require a 24-v source (no “C” connection required), use a thermostat cable or equivalent with minimum of six leads. Check the thermostat

installation instructions for additional features which might require additional conductors in the cable.

For wire runs up to 15 m (50 ft.), use no. 18 AWG (American Wire Gage) insulated wire (35°C minimum). For 15 to 23 m (50 to 75 ft.), use no. 16 AWG insulated wire (35°C minimum). For over 23 m (75 ft.), use no. 14 AWG insulated wire (35°C minimum). All wire sizes larger than no. 18 AWG cannot be directly connected to the thermostat and will require a junction box and splice at the thermostat.

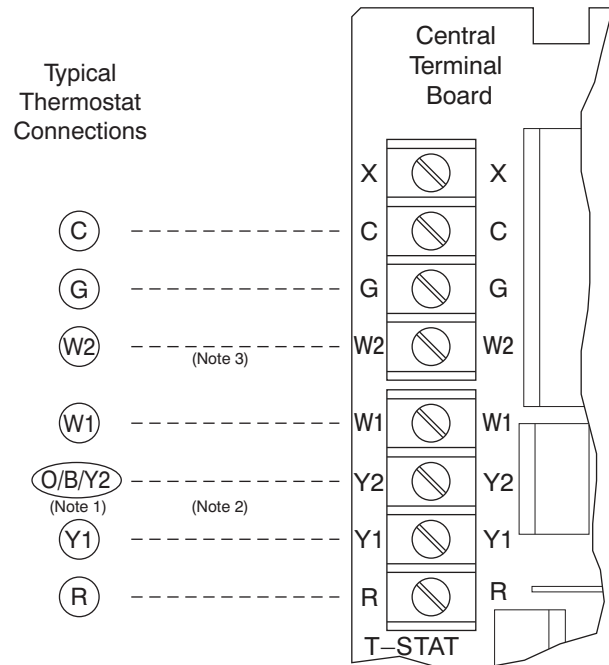

Note 1: Typical multi-function marking. Follow manufacturer’s configuration instructions to select Y2.

Note 2: Y2 to Y2 connection required on single-stage cooling units when integrated economizer function is desired

Note 3: W2 connection not required on units with single-stage heating.

--- Field Wiring

C09459

Fig. 20 - Typical Low-Voltage Control Connections

Unit without thru-base connection kit —

Pass the thermostat control wires through the hole provided in the end panel (see item “D” in the view labeled “LEFT” in Fig. 1 and Fig. 2); then feed the wires through the raceway built into the corner post to the control box. Pull the wires over to the terminal strip on the upper-left corner of the Central Terminal Board. (CTB) See Fig. 21.

NOTE: If thru-the-bottom connections accessory is used, refer to the accessory installation instructions for information on routing power and control wiring.

Heat Anticipator Settings —

Set heat anticipator settings at 0.14 amp for the first stage and 0.14 amp for second-stage heating, when available.

Table 3 – Heater Model Number

Bare Heater Model Number	C	R	H	E	A	T	E	R	0	1	6	A	0	0
Heater Sales Package PNO Includes: Bare Heater Carton and packing materials Installation sheet	C	R	H	E	A	T	E	R	1	1	6	A	0	0

Electric Heaters

50TC units may be equipped with field-installed accessory electric heaters. Each heater is a pre-assembled module, with heater frames holding open coil resistance wires strung through ceramic insulators, line-break limit switches and two control contactors for two-stage heating control.

The heater module is installed in the compartment below the indoor (supply) fan outlet. Access is through the indoor access panel. Heater modules slide into the compartment on tracks along the bottom of the heater opening. See Fig. 22, Fig. 23 and Fig. 24. Refer to the Electric Heater Kit Installation Instructions for complete details.

Not all available heater modules may be used in every unit. Use only those heater modules that are Carrier approved for use in a specific size. Refer to the label on the unit cabinet for the list of approved heaters.

Unit heaters are marked with Heater Model Numbers. But heaters are ordered as and shipped in cartons marked with a corresponding heater Sales Package part number. See Table 3 for correlation between heater Model Number and Sales Package part number.

NOTE: The value in position 9 of the part number differs between the sales package part number (value is 1) and a bare heater model number (value is 0).

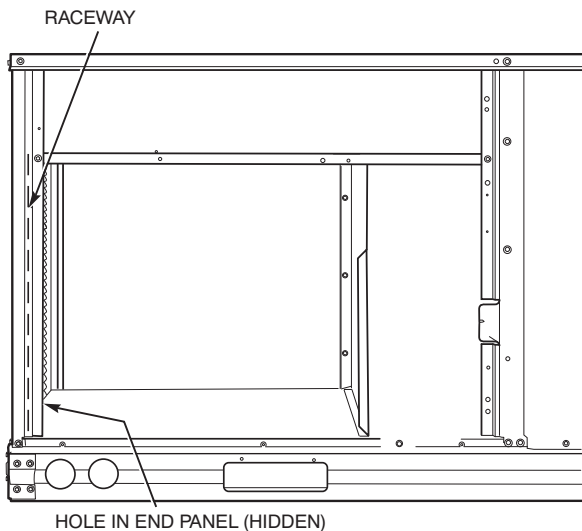

Fig. 21 - Field Control Wiring Raceway C08027

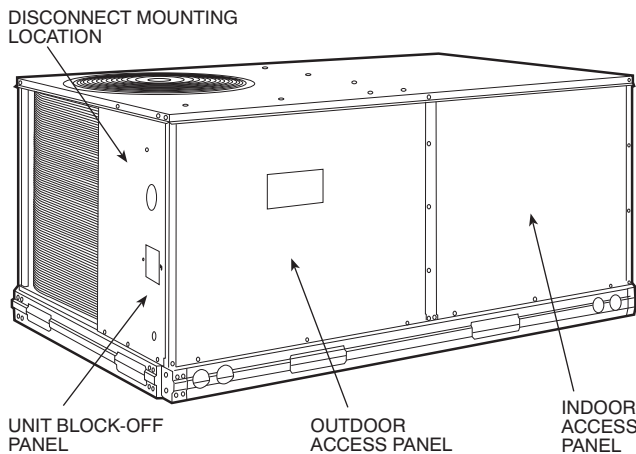

Fig. 22 - Typical Access Panel Location (3-6 Ton) C08133

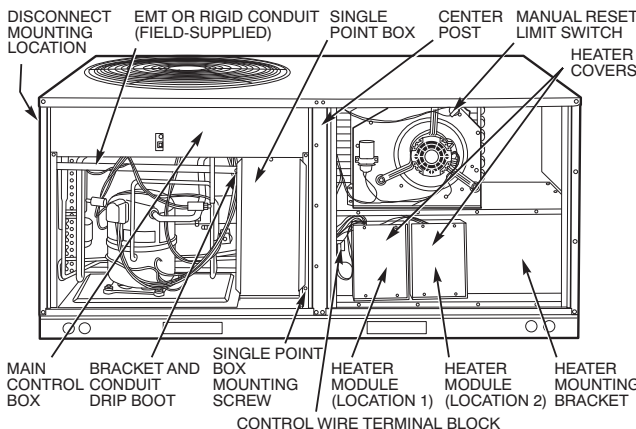
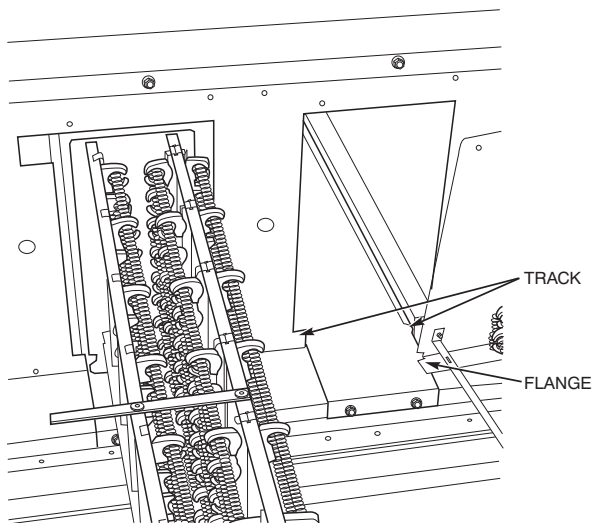

Fig. 23 - Typical Component Location C08134

50TC



C08135

Fig. 24 - Typical Module Installation

Single Point Boxes and Supplementary Fuses — When the unit MOCB device value exceeds 60-A, unit-mounted supplementary fuses are required for each heater circuit. These fuses are included in accessory Single Point Boxes, with power distribution and fuse blocks. The single point box will be installed directly under the unit control box, just to the left of the partition separating the indoor section (with electric heaters) from the outdoor section. The Single Point Box has a hinged access cover. See Fig. 25. The Single Point Box also includes a set of power taps to complete the wiring between the Single Point Box and the unit's main control box terminals. Refer to the accessory heater and Single Point Box installation instructions for details on tap connections.

All fuses on 50TC units are 60-A. (Note that all heaters are qualified for use with a 60-A fuse, regardless of actual heater ampacity, so only 60-A fuses are necessary.)

Single Point Boxes without Fuses — Unit heater applications not requiring supplemental fuses require a special Single Point Box without any fuses. The accessory Single Point Boxes contain a set of power taps to complete the wiring between the Single Point Box and the unit's main control box terminals. Refer to accessory heater and Single Point Box installation instructions for details on tap connections.

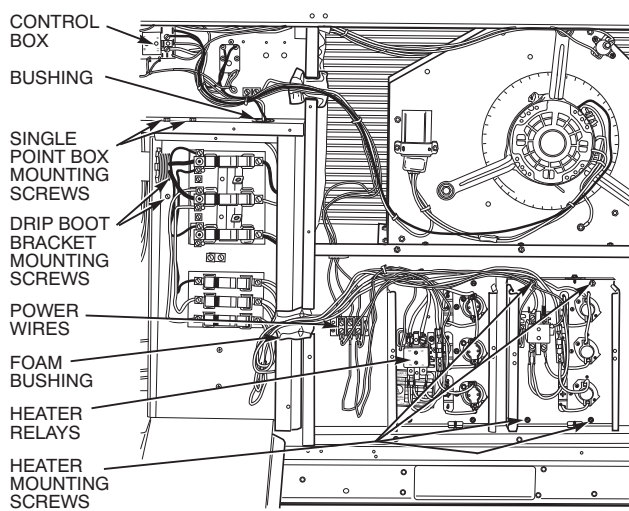

C08136

Fig. 25 - Typical Single Point Installation

Low-Voltage Control Connections — Pull the low-voltage control leads from the heater module(s) - VIO and BRN (two of each if two modules are installed; identify for Module #1) - to the 4-pole terminal board TB4 located on the heater bulkhead to the left of Heater #1. Connect the VIO lead from Heater #1 to terminal TB4-1. For 2 stage heating, connect the VIO lead from Heater #2 to terminal TB4-2. For 1 stage heating with 2 heater modules connect the VIO lead from both Heater #1 and #2 to terminal TB4-1. Connect both BRN leads to terminal TB4-3. See Fig. 26.

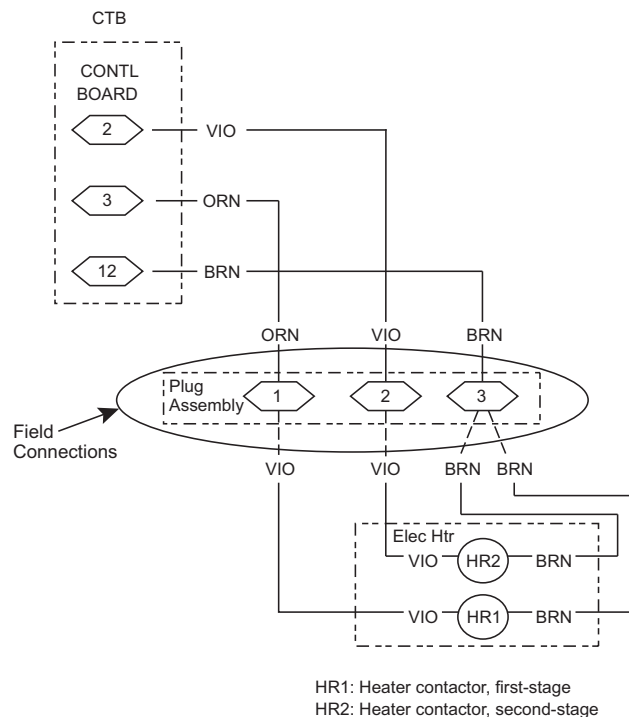

C09390

Fig. 26 - Accessory Electric Heater Control Connections

50TC

PremierLink™ (Factory-Option) —

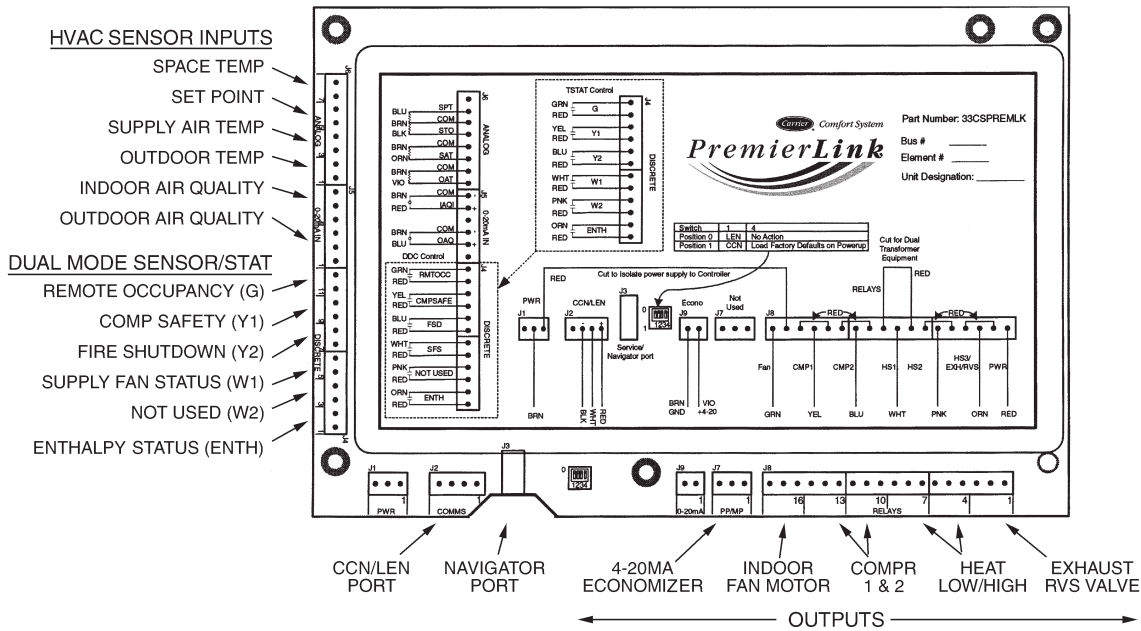

Fig. 27 - PremierLink Controller

C08199

The PremierLink controller (see Fig. 27) is compatible with Carrier Comfort Network® (CCN) devices. This control is designed to allow users the access and ability to change factory-defined settings, thus expanding the function of the standard unit control board. CCN service access tools include System Pilot (TM), Touch Pilot (TM) and Service Tool. (Standard tier display tools Navigator™ and Scrolling Marquee are not suitable for use with latest PremierLink controller (Version 2.x).)

The PremierLink control is factory-mounted in the 50TC unit's main control box to the left of the Central Terminal Board (CTB). Factory wiring is completed through harnesses connected to the CTB pin connectors. Field connections are made at a 16-pole terminal block (TB1) located on the bottom shelf of the unit control box in front of the PremierLink controller. The factory-installed PremierLink control includes the supply-air temperature (SAT) sensor. The outdoor air temperature (OAT) sensor is included in the FIOP/accessory EconoMi\$er™ 2 package.

The PremierLink controller requires the use of a Carrier electronic thermostat or a CCN connection for time broadcast to initiate its internal timeclock. This is necessary for broadcast of time of day functions (occupied/unoccupied).

NOTE: PremierLink controller is shipped in Sensor mode. To be used with a thermostat, the PremierLink controller must be configured to Thermostat mode. Refer to PremierLink Configuration instructions for Operating Mode.

Supply Air Temperature (SAT) Sensor — On FIOP-equipped 50TC unit, the unit is supplied with a supply-air temperature (SAT) sensor (33ZCSENSAT). This sensor is a tubular probe type, approx 152 mm (6-inches) in length. It is a nominal 10-k ohm thermistor.

The SAT is factory-wired. The SAT probe is wire-tied to the supply-air opening (on the horizontal opening end) in its shipping position. Remove the sensor for installation. Re-position the sensor in the flange of the supply-air opening or in the supply air duct (as required by local codes). Drill or punch a 12.7 mm (1/2-in.) hole in the flange or duct. Use two field-supplied, self-drilling screws to secure the sensor probe in a horizontal orientation. See Fig. 28.

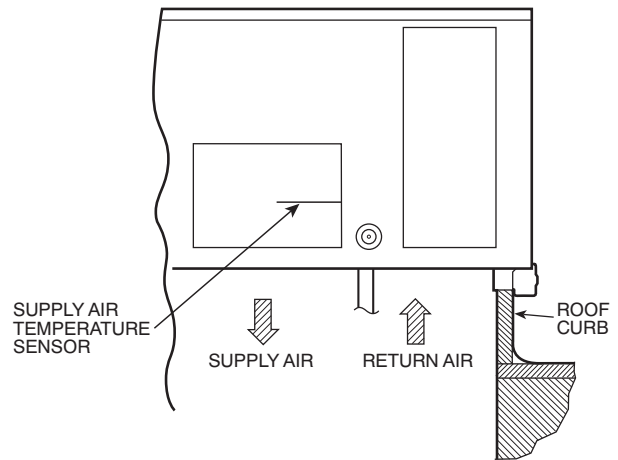

Fig. 28 - Typical Mounting Location for Supply Air Temperature (SAT) Sensor on Small Rooftop Units

C09059

NOTE: Refer to Form 33CS-58SI for complete PremierLink configuration, operating sequences and troubleshooting information. Have a copy of this manual available at unit start-up.

NOTE: The sensor must be mounted in the discharge airstream downstream of the cooling coil and any heating devices. Be sure the probe tip does not come in contact with any of the unit's heater surfaces.

PAC CONTROL 400V-3PH-50HZ
DUAL COMPRESSOR

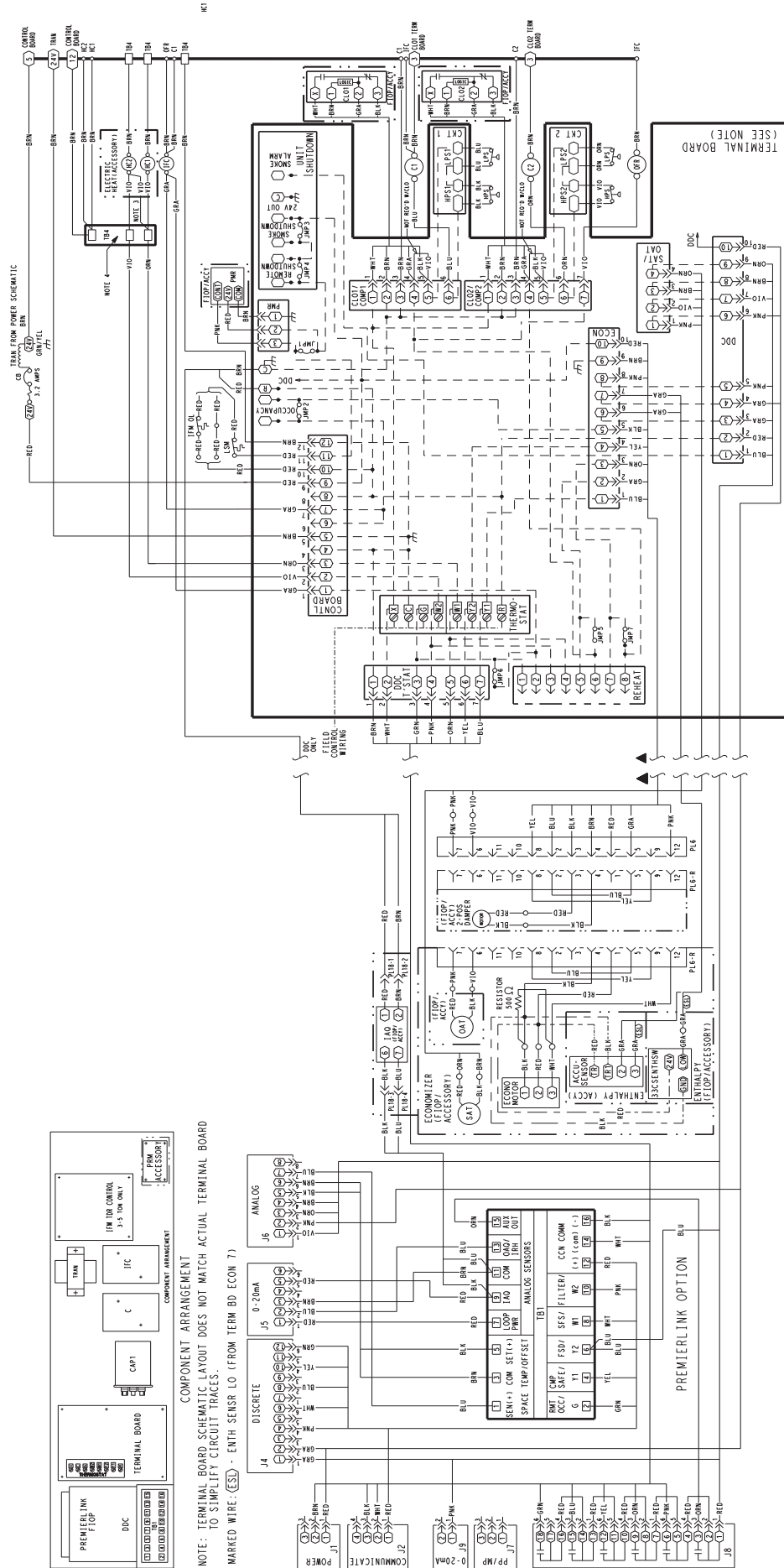

Fig. 29 - PremierLink Wiring Schematic

Outdoor Air Temperature (OAT) Sensor — The OAT is factory-mounted in the EconoMiSer2 (FIOP or accessory). It is a nominal 10k ohm thermistor attached to an eyelet mounting ring.

EconoMiSer2 — The PremierLink control is used with EconoMiSer2 (option or accessory) for outdoor air management. The damper position is controlled directly by the PremierLink control; EconoMiSer2 has no internal logic device.

Outdoor air management functions can be enhanced with field-installation of these accessory control devices:

- Enthalpy control (outdoor air or differential sensors)
- Space CO₂ sensor
- Outdoor air CO₂ sensor

Refer to Table 4 for accessory part numbers.

Field connections — Field connections for accessory sensor and input devices are made at the 16-pole terminal

block (TB1) located on the control box bottom shelf in front of the PremierLink control (See Fig. 29). Some input devices also require a 24-vac signal source; connect at CTB terminal R at “THERMOSTAT” connection strip for this signal source. See connections figures on following pages for field connection locations (and for continued connections at the PremierLink board inputs).

Table 5 provides a summary of field connections for units equipped with Space Sensor. Table 6 provides a summary of field connections for units equipped with Space Thermostat.

Space Sensors - The PremierLink controller is factory-shipped configured for Space Sensor Mode. A Carrier T-55 or T-56 space sensor must be used. T-55 space temperature sensor provides a signal of space temperature to the PremierLink control. T-56 provides same space temperature signal plus it allows for adjustment of space temperature setpoints from the face of the sensor by the occupants.

Table 4 – PremierLink Sensor Usage

APPLICATION	OUTDOOR AIR TEMPERATURE SENSOR	RETURN AIR TEMPERATURE SENSOR	OUTDOOR AIR ENTHALPY SENSOR	RETURN AIR ENTHALPY SENSOR
Differential Dry Bulb Temperature with PremierLink (PremierLink requires 4–20 mA Actuator)	Included – CRTEMPSN001A00	Required – 33ZCT55SPT or equivalent	–	–
Single Enthalpy with PremierLink (PremierLink requires 4–20mA Actuator)	Included – Not Used	–	Requires – HH57AC077 or equivalent	–
Differential Enthalpy with PremierLink (PremierLink requires 4–20mA Actuator)	Included – Not Used	–	Requires – HH57AC077 or equivalent	Requires – HH57AC078 or equivalent

NOTES:

CO₂ Sensors (Optional):

- 33ZCSENC02 – Room sensor (adjustable). Aspirator box is required for duct mounting of the sensor.
- 33ZCASPC02 – Aspirator box used for duct-mounted CO₂ room sensor.
- 33ZCT55CO2 – Space temperature and CO₂ room sensor with override.
- 33ZCT56CO2 – Space temperature and CO₂ room sensor with override and setpoint.

Table 5 – Space Sensor Mode

TB1 TERMINAL	FIELD CONNECTION	INPUT SIGNAL
1	T55 – SEN/T56 – SEN	Analog (10k thermistor)
2	RMT OCC	Discrete, 24VAC
3	T55 – SEN/T56 – SEN	Analog (10k thermistor)
4	CMPSAFE	Discrete, 24VAC
5	T56 – SET	Analog (10k thermistor)
6	FSD	Discrete, 24VAC
7	LOOP – PWR	Analog, 24VDC
8	SPS	Discrete, 24VAC
9	IAQ – SEN	Analog, 4 – 20mA
10	FILTER	Discrete, 24VAC
11	IAQ – COM/OAQ – COM/RH – COM	Analog, 4 – 20mA
12	CCN + (RED)	Digital, , 5VDC
13	OAQ – SEN/RH – SEN	Analog, 4 – 20mA
14	CCN Gnd (WHT)	Digital, 5VDC
15		
16	CCN – (BLK)	Digital, 5VDC

LEGEND:

- | | | | |
|---------|---|-----|--|
| T55 | – Space Temperature Sensor | FSD | – Fire Shutdown |
| T56 | – Space Temperature Sensor | IAQ | – Indoor Air Quality (CO ₂) |
| CCN | – Carrier Comfort Network (communication bus) | OAQ | – Outdoor Air Quality (CO ₂) |
| CMPSAFE | – Compressor Safety | RH | – Relative Humidity |
| FILTER | – Dirty Filter Switch | SFS | – Supply Fan Status |

Table 6 – Thermostat Mode

TB1 TERMINAL	FIELD CONNECTION	INPUT SIGNAL
1	RAT SEN	Analog (10k thermistor)
2	G	Discrete, 24VAC
3	RAT SEN	Analog (10k thermistor)
4	Y1	Discrete, 24VAC
5		
6	Y2	Discrete, 24VAC
7	LOOP – PWR	Analog, 24VDC
8	W1	Discrete, 24VAC
9	IAQ – SEN	Analog, 4 – 20mA
10	W2	Discrete, 24VAC
11	IAQ – COM/OAQ – COM/RH – COM	Analog, 4 – 20mA
12	CCN + (RED)	Digital, 5VDC
13	OAQ – SEN/RH – SEN	Analog, 4 – 20mA
14	CCN Gnd (WHT)	Digital, 5VDC
15		
16	CCN – (BLK)	Digital, 5VDC

LEGEND:

- | | | | |
|-----|---|----|---------------------------|
| CCN | – Carrier Comfort Network (communication bus) | RH | – Relative Humidity |
| G | – Thermostat Fan | W1 | – Thermostat Heat Stage 1 |
| IAQ | – Indoor Air Quality (CO ₂) | W2 | – Thermostat Heat Stage 2 |
| OAQ | – Outdoor Air Quality (CO ₂) | Y1 | – Thermostat Cool Stage 1 |
| RAT | – Return Air Temperature | Y2 | – Thermostat Cool Stage 2 |

50TC

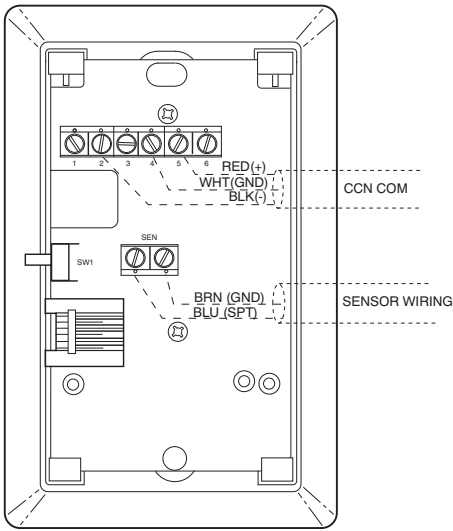

Fig. 30 - T-55 Space Temperature Sensor Wiring

C08201

Connect T-55 - See Fig. 30 for typical T-55 internal connections. Connect the T-55 SEN terminals to TB1 terminals 1 and 3 (see Fig. 31).

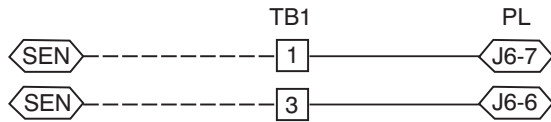

Fig. 31 - PremierLink T-55 Sensor

C08212

Connect T-56 - See Fig. 32 for T-56 internal connections. Install a jumper between SEN and SET terminals as illustrated. Connect T-56 terminals to TB1 terminals 1, 3 and 5 (see Fig. 33).

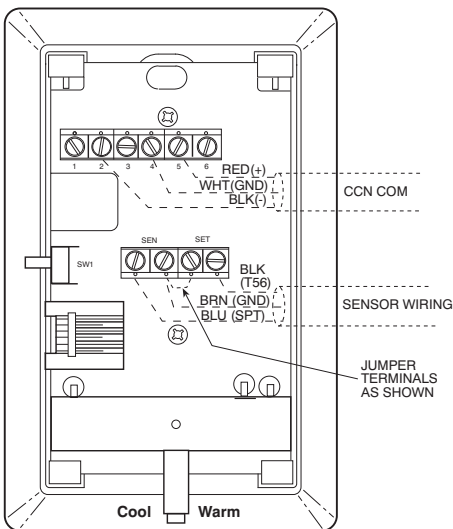

Fig. 32 - T-56 Internal Connections

C08202

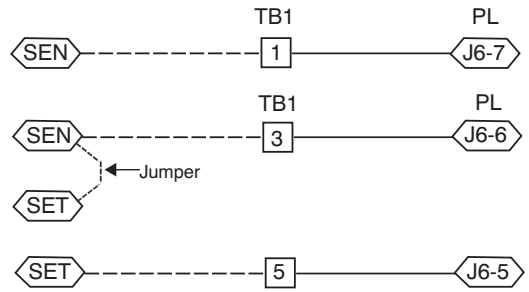

Fig. 33 - PremierLink T-56 Sensor

C08213

Connect Thermostat — A 7-wire thermostat connection requires a 24-v power source and a common connection. Use the R and C terminals on the CTB's THERMOSTAT connection strip for these. Connect the thermostat's Y1, Y2, W1, W2 and G terminals to PremierLink TB1 as shown in Fig. 34.

If the 50TC unit is equipped with factory-installed smoke detector(s), disconnect the factory BLU lead at TB1-6 (Y2) before connecting the thermostat. Identify the BLU lead originating at CTB-DDC-1; disconnect at TB1-6 and tape off. Confirm that the second BLU lead at TB1-6 remains connected to PremierLink J4-8.

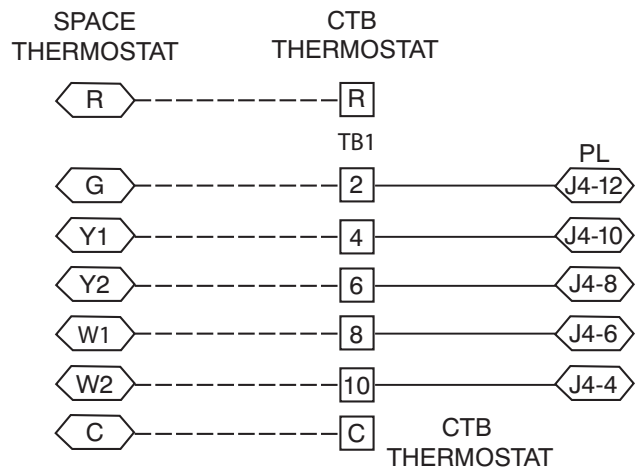

Fig. 34 - Space Thermostat Connections

C08119

If the 50TC unit has an economizer system and free-cooling operation is required, a sensor representing Return Air Temperature must also be connected (field-supplied and installed). This sensor may be a T-55 Space Sensor (see Fig. 29) installed in the space or in the return duct, or it may be sensor PNO 33ZCSENSAT, installed in the return duct. Connect this sensor to TB1-1 and TB1-3 per Fig. 31.

Configure the unit for Thermostat Mode — Connect to the CCN bus using a CCN service tool and navigate to PremierLink Configuration screen for Operating Mode. Default setting is Sensor Mode (value 1). Change the value to 0 to reconfigure the controller for Thermostat Mode.

When the PremierLink is configured for Thermostat Mode, these functions are not available: Fire Shutdown (FSD), Remote Occupied (RMT OCC), Compressor Safety (CMPSAFE), Supply Fan Status (SFS), and Filter Pressure Switch (FILTER).

Economizer controls —

Outdoor Air Enthalpy Control (PNO HH57AC077) -

The enthalpy control (HH57AC077) is available as a field-installed accessory to be used with the EconoMi\$er2 damper system. The outdoor air enthalpy sensor is part of the enthalpy control. (The separate field-installed accessory return air enthalpy sensor (HH57AC078) is required for differential enthalpy control. See Fig. 35.)

Locate the enthalpy control in the economizer hood. Locate two GRA leads in the factory harness and connect these leads to enthalpy control sensors 2 and 3. See Fig. 35. Connect the enthalpy control power input terminals to economizer actuator power leads RED (connect to TR) and BLK (connect to TR1).

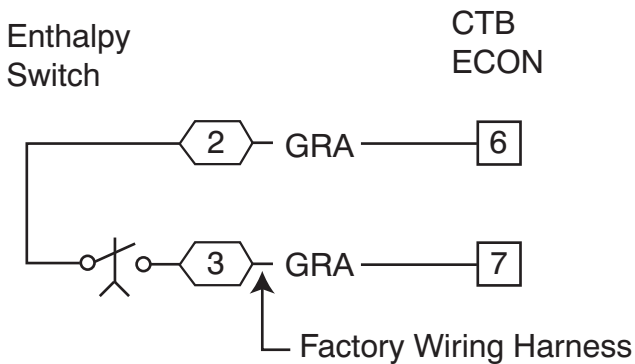

C08218

Fig. 35 - Enthalpy Switch (HH57AC077) Connections

The outdoor enthalpy changeover setpoint is set at the enthalpy controller.

Differential Enthalpy Control — Differential enthalpy control is provided by sensing and comparing the outside air and return air enthalpy conditions. Install the outdoor air enthalpy control as described above. Add and install a return air enthalpy sensor.

Return Air Enthalpy Sensor — Mount the return-air enthalpy sensor (HH57AC078) in the return-air duct. The return air sensor is wired to the enthalpy controller (HH57AC077). See Fig. 36.

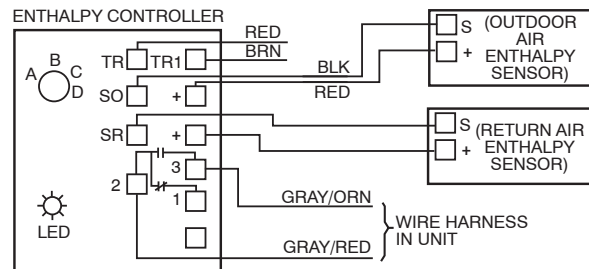

NOTES:

1. Remove factory-installed jumper across SR and + before connecting wires from return air sensor.
2. Switches shown in high outdoor air enthalpy state. Terminals 2 and 3 close on low outdoor air enthalpy relative to indoor air enthalpy.
3. Remove sensor mounted on back of control and locate in outside airstream.

C06019

Fig. 36 - Outside and Return Air Enthalpy Sensor Wiring

To wire the return air enthalpy sensor, perform the following:

1. Use a 2-conductor, 18 or 20 AWG, twisted pair cable to connect the return air enthalpy sensor to the enthalpy controller.
2. At the enthalpy control remove the factory-installed resistor from the (SR) and (+) terminals.
3. Connect the field-supplied RED wire to (+) spade connector on the return air enthalpy sensor and the (SR+) terminal on the enthalpy controller. Connect the BLK wire to (S) spade connector on the return air enthalpy sensor and the (SR) terminal on the enthalpy controller.

NOTE: The enthalpy control must be set to the “D” setting for differential enthalpy control to work properly.

Indoor Air Quality (CO₂ sensor) — The indoor air quality sensor accessory monitors space carbon dioxide (CO₂) levels. This information is used to monitor IAQ levels. Several types of sensors are available, for wall mounting in the space or in return duct, with and without LCD display, and in combination with space temperature sensors. Sensors use infrared technology to measure the levels of CO₂ present in the space air.

The CO₂ sensors are all factory set for a range of 0 to 2000 ppm and a linear mA output of 4 to 20. Refer to the instructions supplied with the CO₂ sensor for electrical requirements and terminal locations. See Fig. 37 for typical CO₂ sensor wiring schematic.

50TC

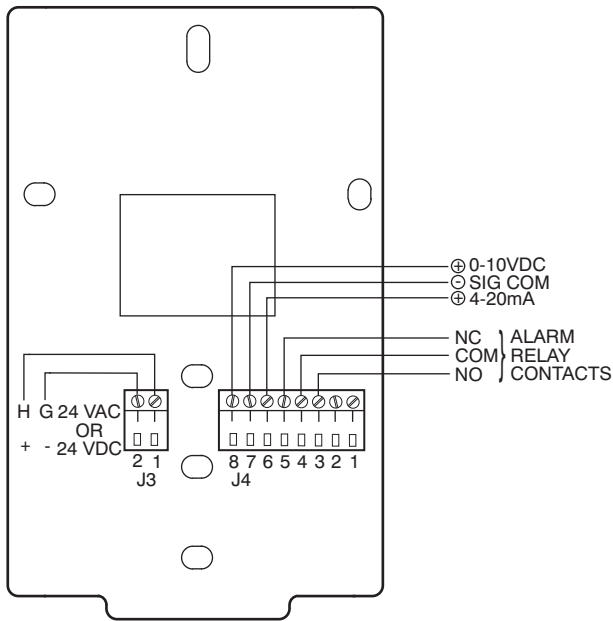

Fig. 37 - Indoor/Outdoor Air Quality (CO₂) Sensor (33ZCSENCO2) - Typical Wiring Diagram

To accurately monitor the quality of the air in the conditioned air space, locate the sensor near a return-air grille (if present) so it senses the concentration of CO₂ leaving the space. The sensor should be mounted in a location to avoid direct breath contact.

Do not mount the IAQ sensor in drafty areas such as near supply ducts, open windows, fans, or over heat sources. Allow at least 0.9 m (3 ft) between the sensor and any corner. Avoid mounting the sensor where it is influenced by the supply air; the sensor gives inaccurate readings if the supply air is blown directly onto the sensor or if the supply air does not have a chance to mix with the room air before it is drawn into the return airstream.

Wiring the Indoor Air Quality Sensor —

For each sensor, use two 2-conductor 18 AWG (American Wire Gage) twisted-pair cables (unshielded) to connect the separate isolated 24 vac power source to the sensor and to connect the sensor to the control board terminals.

To connect the sensor to the control, identify the positive (4 to 20 mA) and ground (SIG COM) terminals on the sensor. See Fig. 37. Connect the 4-20 mA terminal to terminal TB1-9 and connect the SIG COM terminal to terminal TB1-11. See Fig. 38.

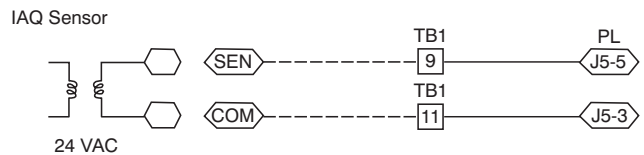

Fig. 38 - Indoor CO₂ Sensor (33ZCSENCO2) Connections

Refer to Form 33CS-58SI, PremierLink Installation, Start-up, and Configuration Instructions, for detailed configuration information

Outdoor Air Quality Sensor (PNO 33ZCSENCO2 plus weatherproof enclosure) — The outdoor air CO₂ sensor is designed to monitor carbon dioxide (CO₂) levels in the outside ventilation air and interface with the ventilation damper in an HVAC system. The OAQ sensor is packaged with an outdoor cover. See Fig. 39. The outdoor air CO₂ sensor must be located in the economizer outside air hood.

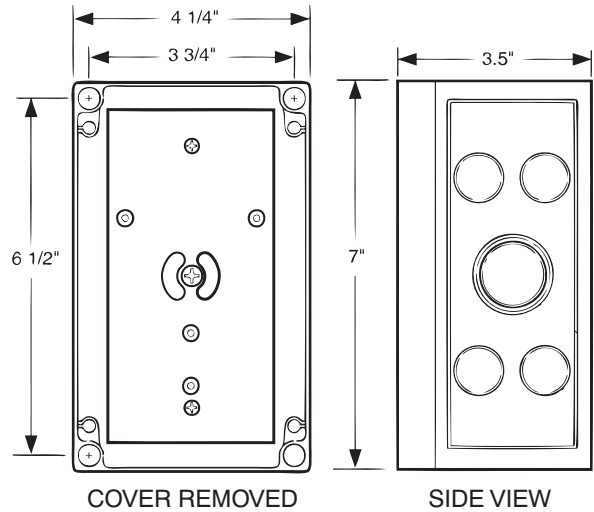

Fig. 39 - Outdoor Air Quality Sensor Cover

Wiring the Outdoor Air CO₂ Sensor — A dedicated power supply is required for this sensor. A two-wire cable is required to wire the dedicated power supply for the sensor. The two wires should be connected to the power supply and terminals 1 and 2.

To connect the sensor to the control, identify the positive (4 to 20 mA) and ground (SIG COM) terminals on the OAQ sensor. See Fig. 37. Connect the 4 to 20 mA terminal to the TB1-13 terminal of the 50TC. Connect the SIG COM terminal to the TB1-11 terminal of the 50TC. See Fig. 40.

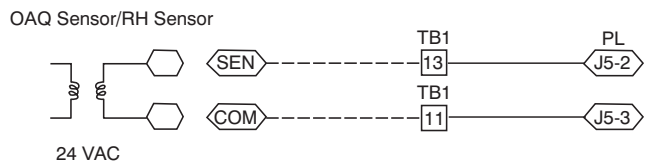

Fig. 40 - Outdoor CO₂ Sensor Connections

Fire Shutdown (FSD) — This function is available only when PremierLink is configured for (Space) Sensor Mode. The unit is factory-wired for PremierLink FSD operation when PremierLink is factory-installed.

Filter Status Switch — This function is available only when PremierLink is configured for (Space) Sensor Mode.

PremierLink control can monitor return filter status in two ways: By monitoring a field-supplied/installed filter pressure switch or via supply fan runtime hours.

Using switch input: Install the dirty filter pressure switch according to switch manufacturer’s instructions, to measure pressure drop across the unit’s return filters. Connect one side of the switch’s NO contact set to CTB’s THERMOSTAT-R terminal. Connect the other side of the NO contact set to TB1-10. Setpoint for Dirty Filter is set at the switch. See Fig. 41.

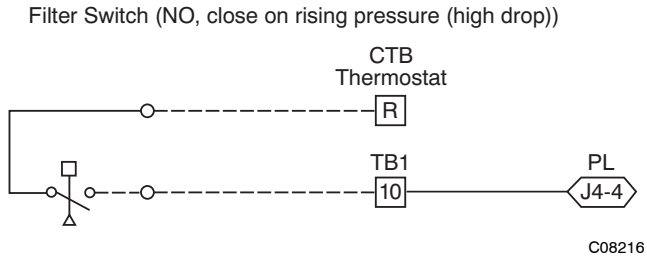

Fig. 41 - PremierLink Filter Switch Connection

When the filter switch’s NO contact set closes as filter pressure drop increases (indicating dirt-laden filters), the input signal to PremierLink causes the filter status point to read “DIRTY”.

Using Filter Timer Hours: Refer to Form 33CS-58SI for instructions on using the PremierLink Configuration screens and on unit alarm sequence.

Supply Fan Status Switch — The PremierLink control can monitor supply fan operation through a field-supplied/installed differential pressure switch. This sequence will prevent (or interrupt) operation of unit cooling, heating and economizer functions until the pressure switch contacts are closed indicating proper supply fan operation.

Install the differential pressure switch in the supply fan section according to switch manufacturer’s instructions. Arrange the switch contact to be open on no flow and to close as pressure rises indicating fan operation.

Connect one side of the switch’s NO contact set to CTB’s THERMOSTAT-R terminal. Connect the other side of the NO contact set to TB1-8. Setpoint for Supply Fan Status is set at the switch. See Fig. 42.

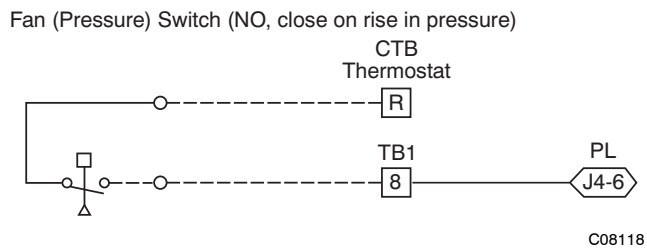

Fig. 42 - PremierLink Wiring Fan Pressure Switch Connection

Remote Occupied Switch — The PremierLink control permits a remote timeclock to override the control’s on-board occupancy schedule and place the unit into

Occupied mode. This function may also provide a “Door Switch” time delay function that will terminate cooling and heating functions after a 2-20 minute delay.

Connect one side of the NO contact set on the timeclock to CTB’s THERMOSTAT-R terminal. Connect the other side of the timeclock contact to the unit’s TB1-2 terminal.

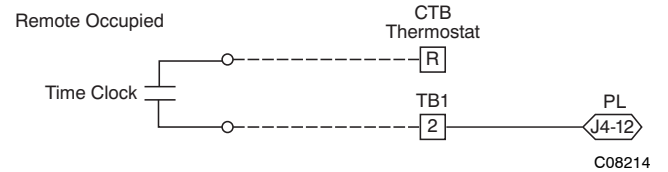

Fig. 43 - PremierLink Wiring Remote Occupied

Refer to Form 33CS-58SI for additional information on configuring the PremierLink control for Door Switch timer function.

Space Relative Humidity Sensor — The RH sensor is not used with these 50Hz 50TC models at this time.

CCN Communication Bus — The PremierLink controller connects to the bus in a daisy chain arrangement. Negative pins on each component must be connected to respective negative pins, and likewise, positive pins on each component must be connected to respective positive pins. The controller signal pins must be wired to the signal ground pins. Wiring connections for CCN must be made at the 3-pin plug.

At any baud (9600, 19200, 38400 baud), the number of controllers is limited to 239 devices maximum. Bus length may not exceed 1219 m (4000 ft), with no more than 60 total devices on any 305 m (1000-ft) section. Optically isolated RS-485 repeaters are required every 305 m (1000 ft).

NOTE: Carrier device default is 9600 band.

COMMUNICATION BUS WIRE SPECIFICATIONS — The CCN Communication Bus wiring is field-supplied and field-installed. It consists of shielded 3-conductor cable with drain (ground) wire. The cable selected must be identical to the CCN Communication Bus wire used for the entire network.

See Table 7 for recommended cable.

Table 7 – Recommended Cables

MANUFACTURER	CABLE PART NO.
Alpha	2413 or 5463
American	A22503
Belden	8772
Columbia	02525

50TC

NOTE: Conductors and drain wire must be at least 20 AWG, stranded, and tinned copper. Individual conductors must be insulated with PVC, PVC/nylon, vinyl, Teflon, or polyethylene. An aluminum/polyester 100% foil shield and an outer jacket of PVC, PVC/nylon, chrome vinyl, or Teflon with a minimum operating temperature range of -20°C to 60°C (-4°F to 140°F) is required. Do not run communication wire in the same conduit as or next to any AC voltage wiring.

The communication bus shields must be tied together at each system element. If the communication bus is entirely within one building, the resulting continuous shield must be connected to ground at only one single point. If the communication bus cable exits from one building and enters another building, the shields must be connected to the grounds at a lightning suppressor in each building (one point only).

Connecting CCN bus:

NOTE: When connecting the communication bus cable, a color code system for the entire network is recommended to simplify installation and checkout. See Table 8 for the recommended color code.

Table 8 – Color Code Recommendations

SIGNAL TYPE	CCN BUS WIRE COLOR	CCN PLUG PIN NUMBER
+	Red	1
Ground	White	2
-	Black	3

Connect the CCN (+) lead (typically RED) to the unit's TB1-12 terminal. Connect the CCN (ground) lead (typically WHT) to the unit's TB1-14 terminal. Connect the CCN (-) lead (typically BLK) to the unit's TB1-16 terminal. See Fig. 44.

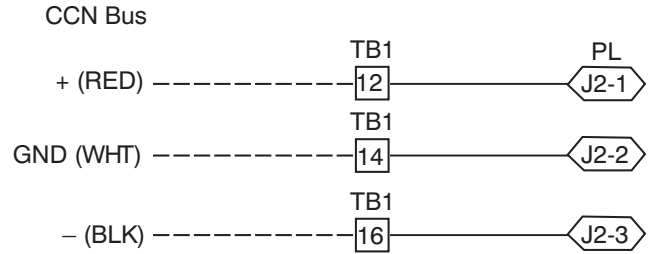

C08276

Fig. 44 - PremierLink CCN Bus Connections

RTU-MP control system

The RTU-MP controller, see Fig. 45, provides expanded stand-alone operation of the HVAC system plus connection and control through communication with several Building Automation Systems (BAS) through popular third-party network systems. The available network systems are BACnet MP/TP, Modbus and Johnson J2. Communication with LonWorks is also possible by adding an accessory interface card to the RTU-MP. Selection of the communication protocol and baud rate are made at on-board DIP switches.

The RTU-MP control is factory-mounted in the 50TC unit's main control box, to the left of the CTB. See Fig. 46. Factory wiring is completed through harnesses connected to the CTB. Field connections for RTU-MP sensors will be made at the Phoenix connectors on the RTU-MP board. The factory-installed RTU-MP control includes the supply-air temperature (SAT) sensor. The outdoor air temperature (OAT) sensor is included in the FIOP/accessory EconoMi\$er2 package.

Refer to Table 9, RTU-MP Controller Inputs and Outputs for locations of all connections to the RTU-MP board.

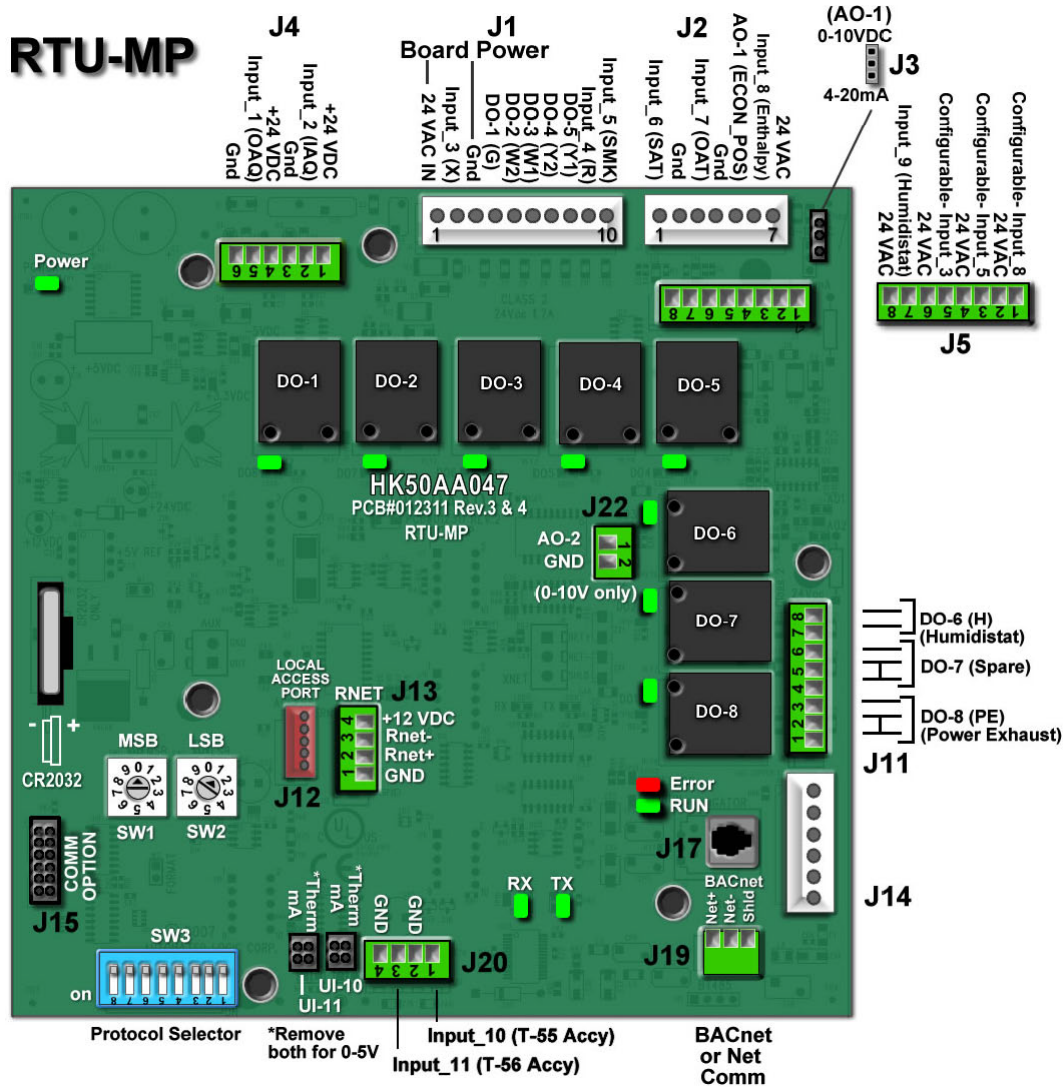

Fig. 45 - RTU-MP Multi-Protocol Control Board

C07129

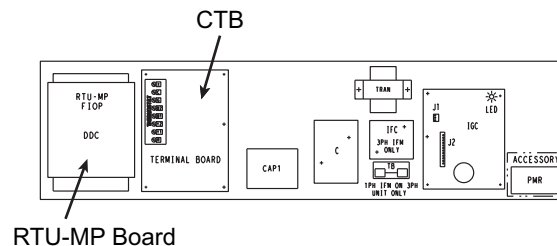

Fig. 46 - 50TC Control Box Component Locations

C08585

PAC CONTROL 400V-3PH-50HZ
DUAL COMPRESSOR

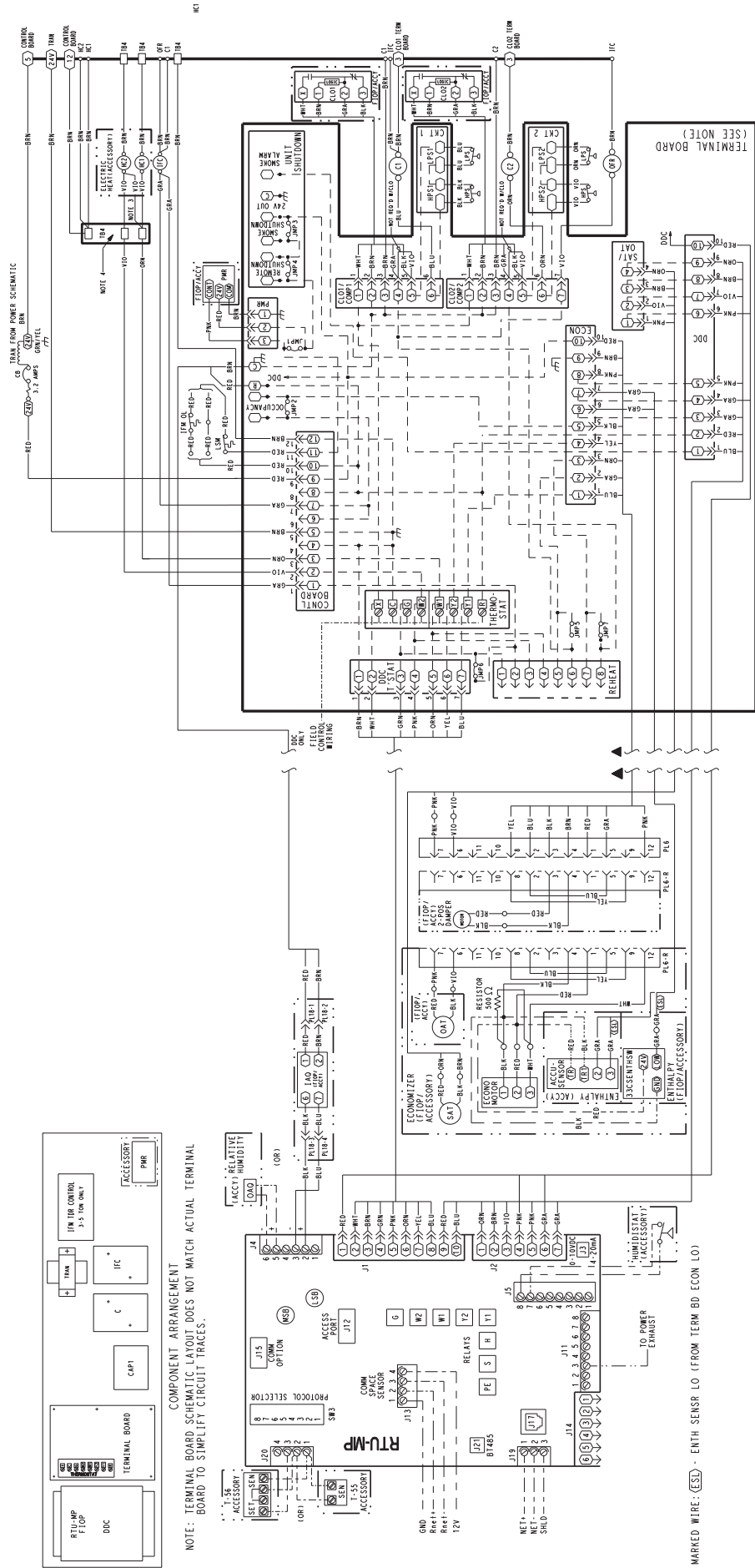

Fig. 47 - RTU-MP System Control Wiring Diagram

Table 9 – RTU-MP Controller Inputs and Outputs

POINT NAME	BACnet OBJECT NAME	TYPE OF I/O	CONNECTION PIN NUMBERS
INPUTS			
Space Temperature Sensor	sptsens	AI (10K Thermistor)	J20–1, 2
Supply Air Temperature	sat	AI (10K Thermistor)	J2–1, 2
Local Outside Air Temperature Sensor	oatsens	AI (10K Thermistor)	J2–3, 4
Space Temperature Offset Pot	sptopot	AI (100K Potentiometer)	J20–3
Indoor Air Quality	iaq	AI (4–20 ma)	J4–2, 3
Outdoor Air Quality	oaq	AI (4–20 ma)	J4–5, 6
Safety Chain Feedback	safety	DI (24 VAC)	J1–9
Compressor Safety	compstat	DI (24 VAC)	J1–2
Fire Shutdown	firedown	DI (24 VAC)	J1–10
Enthalpy Switch	enthalpy	DI (24 VAC)	J2–6, 7
Humidistat Input Status	humstat	DI (24 VAC)	J5–7, 8
CONFIGURABLE INPUTS*			
Space Relative Humidity	sprh	AI (4–20 ma)	J4–2,3 or J4–5,6
Outside Air Relative Humidity	oarh	AI (4–20 ma)	
Supply Fan Status	fanstat	DI (24 VAC)	J5–1,2 or J5–3,4 or J5 5,6 or J5–7,8
Filter Status	filtstat	DI (24 VAC)	
Remote Occupancy Input	remocc	DI (24 VAC)	
OUTPUTS			
Economizer Commanded Position	econocmd	4–20ma	J2–5
Supply Fan Relay State	sf	DO Relay (24VAC , 1A)	J1–4
Compressor 1 Relay State	comp_1	DO Relay (24VAC , 1A)	J1–8
Compressor 2 Relay State	comp_2	DO Relay (24VAC , 1A)	J1–7
Heat Stage 1 Relay State	heat_1	DO Relay (24VAC , 1A)	J1–6
Heat Stage 2 Relay State	heat_2	DO Relay (24VAC , 1A)	J1–5
Power Exhaust Relay State	aux_2	DO Relay (24VAC , 1A)	J11–3
Dehumidification Relay State	humizer	DO Relay (24VAC, 1A)	J11–7, 8

LEGEND

- AI** – Analog Input
- AO** – Analog Output
- DI** – Discrete Input
- DO** – Discrete Output

* These inputs (if installed) take the place of the default input on the specific channel according to schematic. Parallel pins J5–1 = J2–6, J5–3 = J1–10, J5–5 = J1–2 are used for field–installation.

The RTU-MP controller requires the use of a Carrier space sensor. A standard thermostat cannot be used with the RTU-MP system.

Supply Air Temperature (SAT) Sensor - On FIOP-equipped 50TC unit, the unit is supplied with a supply-air temperature (SAT) sensor (33ZCSENSAT). This sensor is a tubular probe type, approx 152 mm (6-inches) in length. It is a nominal 10-k ohm thermistor.

The SAT is factory-wired. The SAT probe is wire-tied to the supply-air opening (on the horizontal opening end) in its shipping position. Remove the sensor for installation. Re-position the sensor in the flange of the supply-air opening or in the supply air duct (as required by local codes). Drill or punch a 12.7 m (1/2-in.) hole in the flange or duct. Use two field-supplied, self-drilling screws to secure the sensor probe in a horizontal orientation. See Fig. 28.

Outdoor Air Temperature (OAT) Sensor - The OAT is factory-mounted in the EconoMiSer2 (FIOP or accessory). It is a nominal 10k ohm thermistor attached to an eyelet mounting ring.

EconoMiSer2 - The RTU-MP control is used with EconoMiSer2 (option or accessory) for outdoor air management. The damper position is controlled directly by the RTU-MP control; EconoMiSer2 has no internal logic device.

Outdoor air management functions can be enhanced with field-installation of these accessory control devices:

- Enthalpy control (outdoor air or differential sensors)
- Space CO₂ sensor
- Outdoor air CO₂ sensor

50TC

Field Connections - Field connections for accessory sensors and input devices are made the RTU-MP, at plugs J1, J2, J4, J5, J11 and J20. All field control wiring that connects to the RTU-MP must be routed through the raceway built into the corner post as shown in Fig. 22. The raceway provides the UL required clearance between high- and low-voltage wiring. Pass the control wires through the hole provided in the corner post, then feed the wires through the raceway to the RTU-MP. Connect to the wires to the removable Phoenix connectors and then reconnect the connectors to the board.

Space Temperature (SPT) Sensors

A field-supplied Carrier space temperature sensor is required with the RTU-MP to monitor space temperature. There are 3 sensors available for this application:

- 33ZCT55SPT, space temperature sensor with override button
- 33ZCT56SPT, space temperature sensor with override button and setpoint adjustment
- 33ZCT59SPT, space temperature sensor with LCD (liquid crystal display) screen, override button, and setpoint adjustment

Use 20 gauge wire to connect the sensor to the controller. The wire is suitable for distances of up to 500 ft. Use a three-conductor shielded cable for the sensor and setpoint adjustment connections. If the setpoint adjustment (slidebar) is not required, then an unshielded, 18 or 20 gauge, two-conductor, twisted pair cable may be used.

Connect T-55 - See Fig. 30 for typical T-55 internal connections. Connect the T-55 SEN terminals to RTU-MP J20-1 and J20-2. See Fig. 48.

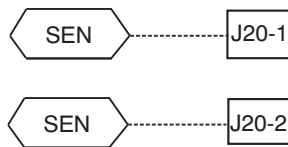

Fig. 48 - RTU-MP T-55 Sensor Connections

C08460

Connect T-56 - See Fig. 32 for T-56 internal connections. Install a jumper between SEN and SET terminals as illustrated. Connect T-56 terminals to RTU-MP J20-1, J20-2 and J20-3 per Fig. 49.

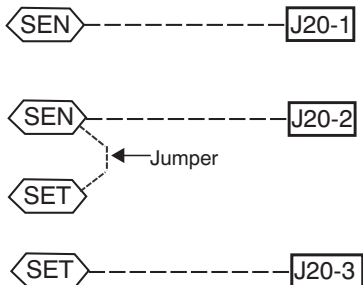
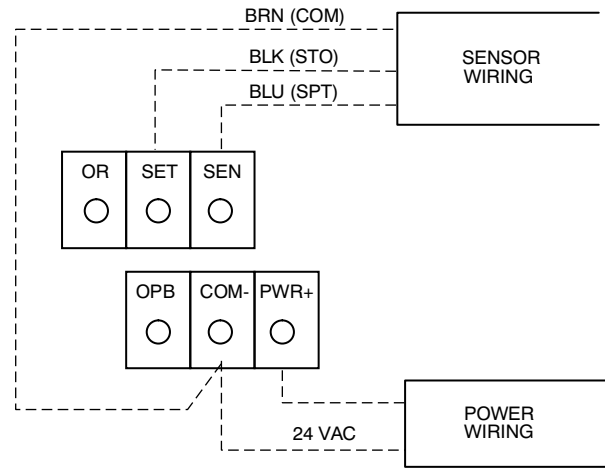

Fig. 49 - RTU-MP T-56 Sensor Connections

C08461

Connect T-59 - The T-59 space sensor requires a separate, isolated power supply of 24 VAC. See Fig. 49 for internal connections at the T-59. Connect the SEN terminal (BLU) to RTU-MP J20-1. Connect the COM terminal (BRN) to J20-2. Connect the SET terminal (STO or BLK) to J20-3.



NOTE: Must use a separate isolated transformer.

C07132

Fig. 50 - Space Temperature Sensor Typical Wiring (33ZCT59SPT)

Economizer controls —

Outdoor Air Enthalpy Control (PNO HH57AC077) -

The enthalpy control (HH57AC077) is available as a field-installed accessory to be used with the EconoMi\$er2 damper system. The outdoor air enthalpy sensor is part of the enthalpy control. (The separate field-installed accessory return air enthalpy sensor (HH57AC078) is required for differential enthalpy control. See “Return Air Enthalpy Sensor” below.)

Locate the enthalpy control in the economizer hood. Locate two GRA leads in the factory harness and connect these leads to enthalpy control sensors 2 and 3. See Fig. 35. Connect the enthalpy control power input terminals to economizer actuator power leads RED (connect to TR) and BLK (connect to TR1).

The outdoor enthalpy changeover setpoint is set at the enthalpy controller.

Differential Enthalpy Control — Differential enthalpy control is provided by sensing and comparing the outside air and return air enthalpy conditions. Install the outdoor air enthalpy control as described above. Add and install a return air enthalpy sensor.

Return Air Enthalpy Sensor — Mount the return-air enthalpy sensor (HH57AC078) in the return-air duct. The return air sensor is wired to the enthalpy controller (HH57AC077). See Fig. 36.

To wire the return air enthalpy sensor, perform the following:

1. Use a 2-conductor, 18 or 20 AWG, twisted pair cable to connect the return air enthalpy sensor to the enthalpy controller.
2. At the enthalpy control remove the factory-installed resistor from the (SR) and (+) terminals.
3. Connect the field-supplied RED wire to (+) spade connector on the return air enthalpy sensor and the (SR+) terminal on the enthalpy controller. Connect the BLK wire to (S) spade connector on the return air enthalpy sensor and the (SR) terminal on the enthalpy controller.

NOTE: The enthalpy control must be set to the “D” setting for differential enthalpy control to work properly.

Indoor Air Quality (CO₂ sensor) — The indoor air quality sensor accessory monitors space carbon dioxide (CO₂) levels. This information is used to monitor IAQ levels. Several types of sensors are available, for wall mounting in the space or in return duct, with and without LCD display, and in combination with space temperature sensors. Sensors use infrared technology to measure the levels of CO₂ present in the space air.

The CO₂ sensors are all factory set for a range of 0 to 2000 ppm and a linear mA output of 4 to 20. Refer to the instructions supplied with the CO₂ sensor for electrical requirements and terminal locations. See Fig. 37 for typical CO₂ sensor wiring schematic.

To accurately monitor the quality of the air in the conditioned air space, locate the sensor near a return-air grille (if present) so it senses the concentration of CO₂ leaving the space. The sensor should be mounted in a location to avoid direct breath contact.

Do not mount the IAQ sensor in drafty areas such as near supply ducts, open windows, fans, or over heat sources. Allow at least 3 ft (0.9 m) between the sensor and any corner. Avoid mounting the sensor where it is influenced by the supply air; the sensor gives inaccurate readings if the supply air is blown directly onto the sensor or if the supply air does not have a chance to mix with the room air before it is drawn into the return airstream.

Wiring the Indoor Air Quality Sensor —

For each sensor, use two 2-conductor 18 AWG (American Wire Gage) twisted-pair cables (unshielded) to connect the separate isolated 24 vac power source to the sensor and to connect the sensor to the RTU-MP control board terminals.

To connect the sensor to the control, identify the positive (4 to 20 mA) and ground (SIG COM) terminals on the sensor. See Fig. 36. Connect the 4-20 mA terminal to RTU-MP J4-2 and connect the SIG COM terminal to RTU-MP J4-3. See Fig. 51.

IAQ Sensor

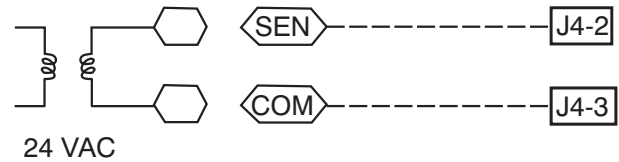

C08462

Fig. 51 - RTU-MP / Indoor CO₂ Sensor (33ZCSENC02) Connections

Outdoor Air Quality Sensor (PNO 33ZCSENC02 plus weatherproof enclosure) — The outdoor air CO₂ sensor is designed to monitor carbon dioxide (CO₂) levels in the outside ventilation air and interface with the ventilation damper in an HVAC system. The OAQ sensor is packaged with an outdoor cover. See Fig. 39. The outdoor air CO₂ sensor must be located in the economizer outside air hood.

Wiring the Outdoor Air CO₂ Sensor — A dedicated power supply is required for this sensor. A two-wire cable is required to wire the dedicated power supply for the sensor. The two wires should be connected to the power supply and terminals 1 and 2.

To connect the sensor to the control, identify the positive (4 to 20 mA) and ground (SIG COM) terminals on the OAQ sensor. See Fig. 37. Connect the 4 to 20 mA terminal to RTU-MP J4-5. Connect the SIG COM terminal to RTU-MP J4-6.

OAQ Sensor/RH Sensor

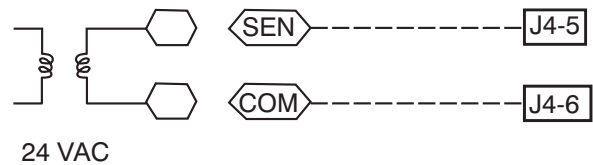

C08463

Fig. 52 - RTU-MP / Outdoor CO₂ Sensor (33ZCSENC02) Connections

Connecting Discrete Inputs

Filter Status

The filter status accessory is a field-installed accessory. This accessory detects plugged filters. When installing this accessory, the unit must be configured for filter status by setting *MENU* → *Config* → *Inputs* → *input 3, 5, 8, or 9* to Filter Status and normally open (N/O) or normally closed (N/C). Input 8 or 9 is recommended for easy of installation. Refer to Fig. 45 and Fig. 47 for wire terminations at J5.

Fan Status

The fan status accessory is a field-installed accessory. This accessory detects when the indoor fan is blowing air. When installing this accessory, the unit must be configured for fan status by setting **MENU** → **Config** → **Inputs** → **input 3, 5, 8, or 9** to Fan Status and normally open (N/O) or normally closed (N/C). Input 8 or 9 is recommended for easy of installation. Refer to Fig. 45 and Fig. 47 for wire terminations at J5.

Remote Occupancy

The remote occupancy accessory is a field-installed accessory. This accessory overrides the unoccupied mode and puts the unit in occupied mode. When installing this accessory, the unit must be configured for remote occupancy by setting **MENU** → **Config** → **Inputs** → **input 3, 5, 8, or 9** to Remote Occupancy and normally open (N/O) or normally closed (N/C).

Also set **MENU** → **Schedules** → **occupancy source** to DI on/off. Input 8 or 9 is recommended for easy of installation. Refer to Fig. 45 and Table 9 for wire terminations at J5.

Space Relative Humidity Sensor - The RH sensor is not used with these 50Hz 50TC models at this time.

Communication Wiring - Protocols

General

Protocols are the communication languages spoken by control devices. The main purpose of a protocol is to communicate information in the most efficient method possible. Different protocols exist to provide different kinds of information for different applications. In the BAS application, many different protocols are used, depending on manufacturer. Protocols do not change the function of a controller; just make the front end user different.

The RTU-MP can be set to communicate on four different protocols: BACnet, Modbus, N2, and LonWorks. Switch 3 (SW3) on the board is used to set protocol and baud rate. Switches 1 and 2 (SW1 and SW2) are used to set the board's network address. See Fig. 53 for the switch setting per protocol. The 3rd party connection to the RTU-MP is through plug J19.

NOTE: Power must be cycled after changing the SW1-3 switch settings.

Refer to the *RTU-MP 3rd Party Integration Guide* for more detailed information on protocols, 3rd party wiring, and networking.

SW3 Protocol Selection

PROTOCOL	DS8	DS7	DS6	DS5	DS4	DS3	DS2	DS1
BACnet MS/TP (Master)	Unused	OFF	OFF	OFF	ON	OFF	Select Baud	Select Baud
Modbus (Slave)	Unused	OFF	OFF	ON	ON	OFF	Select Baud	Select Baud
N2 (Slave)	Unused	OFF	OFF	OFF	ON	ON	OFF	OFF
LonWorks	Unused	ON	ON	OFF	ON	OFF	OFF	OFF

NOTE:
DS = Dip Switch
BACnet MS/TP SW3 example shown

Baud Rate Selections

BAUD RATE	DS2	DS1
9600	OFF	OFF
19,200	ON	OFF
38,400	OFF	ON
76,800	ON	ON

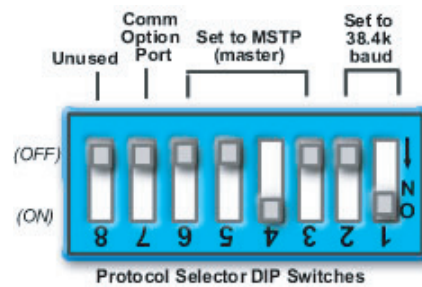

C07166

Fig. 53 - RTU-MP SW3 Dip Switch Settings

Local Access

BACview⁶ Handheld

The BACview⁶ is a keypad/display interface used to connect to the RTU-MP to access the control information, read sensor values, and test the RTU, see Fig. 54. This is an accessory interface that does not come with the MP controller and can only be used at the unit. Connect the BACview⁶ to the RTU-MP's J12 local access port. There are 2 password protected levels in the display (User and Admin). The user password is defaulted to 0000 but can be changed. The Admin password is 1111 and cannot be changed. There is a 10 minute auto logout if a screen is idle. See Form 48-50H-T-2T, Appendix A for navigation and screen content.

Virtual BACview

Virtual BACview is a freeware computer program that functions as the BACview⁶ Handheld. The USB Link

interface (USB-L) is required to connect a computer to the RTU-MP board. The link cable connects a USB port to the J12 local access port. This program functions and operates identical to the handheld.

RTU-MP Troubleshooting

Communication LEDs

The LEDs indicate if the controller is speaking to the devices on the network. The LEDs should reflect communication traffic based on the baud rate set. The higher the baud rate the more solid the LEDs will appear. See Table 10 for further details.

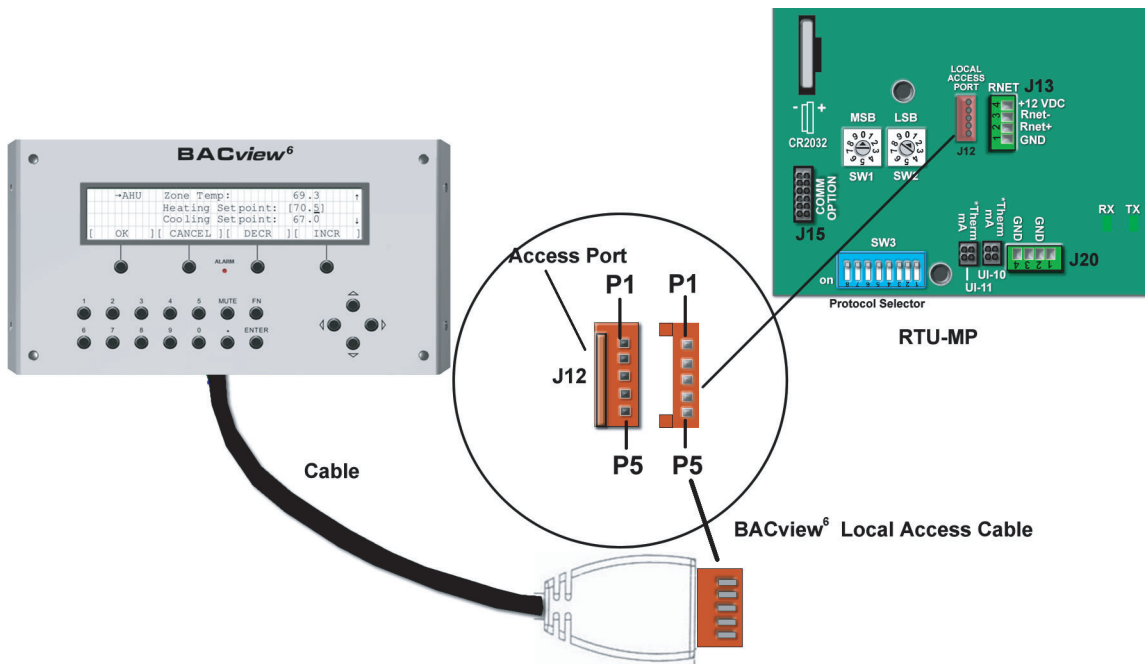

Fig. 54 - BACview⁶ Handheld Connections

50TC

C07170

Table 10 – LEDs

The LEDs on the RTU-MP show the status of certain functions

If this LED is on...	Status is...
Power	The RTU MP has power
Rx	The RTU MP is receiving data from the network segment
Tx	The RTU MP is transmitting data over the network segment
DO#	The digital output is active

The **Run** and **Error** LEDs indicate control module and network status

If Run LED shows...	And Error LED shows...	Status is...
2 flashes per second	Off	Normal
2 flashes per second	2 flashes, alternating with Run LED	Five minute auto-restart delay after system error
2 flashes per second	3 flashes, then off	Control module has just been formatted
2 flashes per second	4 flashes, then pause	Two or more devices on this network have the same ARC156 network address
2 flashes per second	On	Exec halted after frequent system errors or control programs halted
5 flashes per second	On	Exec start-up aborted, Boot is running
5 flashes per second	Off	Firmware transfer in progress, Boot is running
7 flashes per second	7 flashes per second, alternating with Run LED	Ten second recovery period after brownout
14 flashes per second	14 flashes per second, alternating with Run LED	Brownout
On	On	Failure. Try the following solutions: <ul style="list-style-type: none"> • Turn the RTU-MP off, then on. • Format the RTU-MP. • Download memory to the RTU-MP. • Replace the RTU-MP.

NOTE: Refer to Form 48-50H-T-2T for complete configuration of RTU-MP, operating sequences and troubleshooting information. Refer to *RTU-MP 3rd Party Integration Guide* for details on configuration and troubleshooting of connected networks. Have a copy of these manuals available at unit start-up.

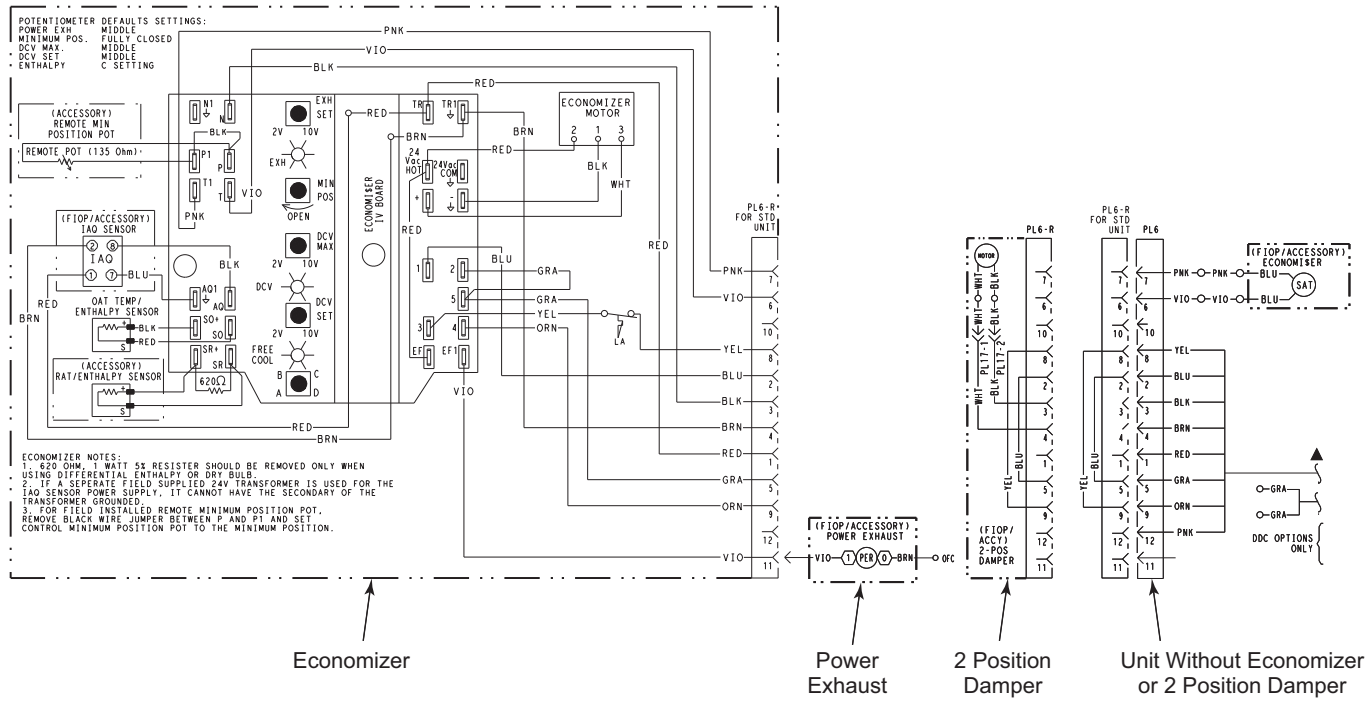

Fig. 55 - EconoMiSer™ IV Wiring

C09382

Step 11 — Adjust Factory-Installed Options

EconoMiSer IV Occupancy Switch —

Refer to Fig. 55 for general EconoMiSer IV wiring. External occupancy control is managed through a connection on the Central Terminal Board.

If external occupancy control is desired, connect a time clock or remotely controlled switch (closed for Occupied, open for Unoccupied sequence) at terminals marked OCCUPANCY on CTB. Remove or cut jumper JMP 2 to complete the installation.

Step 12 — Install Accessories

Available accessories include:

- Roof Curb
- Thru-base connection kit (must be installed before unit is set on curb)
- Manual outside air damper
- Two-Position motorized outside air damper
- EconoMiSer IV (with control and integrated barometric relief)
- EconoMiSer2 (without control/for external signal and integrated barometric relief)

- Differential dry-bulb sensor (EconoMiSer IV)
- Outdoor enthalpy sensor
- Differential enthalpy sensor
- Electric Heaters
- Single Point kits
- Low Ambient Controls
- Thermostat / Sensors
- CO₂ sensor
- DDC interface (PremierLink)
- Louvered hail guard
- Phase monitor control
- Winter Start kit

Refer to separate installation instructions for information on installing these accessories.

Pre-Start and Start-Up

This completes the mechanical installation of the unit. Refer to the unit's Service Manual for detailed Pre-Start and Start-up instructions.

Table 11 – Unit Wire/MOCP Sizing Data

UNIT	NOM. V – PH – HZ	IFM TYPE	ELECTRIC HEATER						
			CRHEATER***A00	Nom (kW)	FLA	MCA	MOCP	DISC. SIZE	
								FLA	LRA
50TC*A07	400 – 3 – 50	STD		–	–	15.4	25	15	75
			CRHEATER106A00	6.0	6.0	15.4	25	15	75
			CRHEATER108A00	11.5	11.5	17.6	25	16	75
			CRHEATER109A00	14.0	14.0	20.8	25	19	75
			CRHEATER108A00,108A00	23.1	23.1	32.1	35	30	75
			CRHEATER108A00,109A00	25.6	25.6	35.3	40	32	75
		HIGH		–	–	16.2	25	16	94
			CRHEATER106A00	6.0	6.0	16.2	25	16	94
			CRHEATER108A00	11.5	11.5	18.6	25	17	94
			CRHEATER109A00	14.0	14.0	21.8	25	20	94
CRHEATER108A00,108A00	23.1		23.1	33.1	35	30	94		
CRHEATER108A00,109A00	25.6	25.6	36.3	40	33	94			
50TC*D08	400 – 3 – 50	STD		–	–	17.5	20	18	99
			CRHEATER116A00	13.9	13.9	20.6	25	19	99
			CRHEATER113A00	16.5	16.5	23.9	25	22	99
			CRHEATER114A00	27.9	27.9	38.1	40	35	99
			CRHEATER115A00	33.1	33.1	44.6	45	41	99
			CRHEATER114A00,116A00	41.8	41.8	55.5	60	51	99
		MED		–	–	18.3	20	19	118
			CRHEATER116A00	13.9	13.9	21.6	25	20	118
			CRHEATER113A00	16.5	16.5	24.9	25	23	118
			CRHEATER114A00	27.9	27.9	39.1	40	36	118
			CRHEATER115A00	33.1	33.1	45.6	50	42	118
		CRHEATER114A00,116A00	41.8	41.8	56.5	60	52	118	
		HIGH		–	–	22.7	30	24	171
			CRHEATER116A00	13.9	13.9	26.6	30	24	171
			CRHEATER113A00	16.5	16.5	29.9	30	27	171
CRHEATER114A00	27.9		27.9	44.1	45	41	171		
CRHEATER115A00	33.1		33.1	50.6	60	47	171		
CRHEATER114A00,116A00	41.8	41.8	61.5	70	57	171			

50TC

NOTE: See page 38 for table legend and notes.

Table 11 – Unit Wire/MOCP Sizing Data (cont)

UNIT	NOM. V – PH – HZ	IFM TYPE	ELECTRIC HEATER			DISC. SIZE			
			CRHEATER***A00	Nom (kW)	FLA	MCA	MOCP	DISC. SIZE	
								FLA	LRA
50TC*D09	400-3-50	STD		-	-	17.5	20	18	108
			CRHEATER116A00	13.9	13.9	20.6	25	19	108
			CRHEATER113A00	16.5	16.5	23.9	25	22	108
			CRHEATER114A00	27.9	27.9	38.1	40	35	108
			CRHEATER115A00	33.1	33.1	44.6	45	41	108
			CRHEATER114A00,116A00	41.8	41.8	55.5	60	51	108
		MED		-	-	17.5	20	18	114
			CRHEATER116A00	13.9	13.9	20.6	25	19	114
			CRHEATER113A00	16.5	16.5	23.9	25	22	114
			CRHEATER114A00	27.9	27.9	38.1	40	35	114
			CRHEATER115A00	33.1	33.1	44.6	45	41	114
			CRHEATER114A00,116A00	41.8	41.8	55.5	60	51	114
		HIGH		-	-	19.3	25	20	172
			CRHEATER116A00	13.9	13.9	22.9	25	21	172
			CRHEATER113A00	16.5	16.5	26.1	30	24	172
			CRHEATER114A00	27.9	27.9	40.4	45	37	172
			CRHEATER115A00	33.1	33.1	46.9	50	43	172
			CRHEATER114A00,116A00	41.8	41.8	57.8	60	53	172
50TC*D12	400-3-50	STD		-	-	21.6	25	23	123
			CRHEATER116A00	13.9	13.9	21.6	25	23	123
			CRHEATER113A00	16.5	16.5	23.9	25	23	123
			CRHEATER115A00	33.1	33.1	44.6	45	41	123
			CRHEATER114A00,116A00	41.8	41.8	55.5	60	51	123
			CRHEATER115A00,113A00	50.1	50.1	53.4	60	61	123
		MED		-	-	23.4	30	25	181
			CRHEATER116A00	13.9	13.9	23.4	30	25	181
			CRHEATER113A00	16.5	16.5	26.1	30	25	181
			CRHEATER115A00	33.1	33.1	46.9	50	43	181
			CRHEATER114A00,116A00	41.8	41.8	57.8	60	53	181
			CRHEATER115A00,113A00	50.1	50.1	55.6	60	63	181
		HIGH		-	-	26.4	30	28	189
			CRHEATER116A00	13.9	13.9	26.6	30	28	189
			CRHEATER113A00	16.5	16.5	29.9	30	28	189
			CRHEATER115A00	33.1	33.1	50.6	60	47	189
			CRHEATER114A00,116A00	41.8	41.8	61.5	70	57	189
			CRHEATER115A00,113A00	50.1	50.1	59.4	70	66	189

NOTE: See page 38 for table legend and notes.

Legend for Table 11

LEGEND:

- DISC - Disconnect
- FLA - Full load amps
- IFM - Indoor fan motor
- LRA - Locked rotor amps
- MCA - Minimum circuit amps
- MOCP - Maximum over current protection

